



CLEAN AIR FURNACE

CAF

Installation Manual

General Notes



Note

- Due to ongoing research and product development, specifications, ratings, and dimensions are subject to change without notice. Refer to www.lifebreath.com for the latest product information.



Attention

- All national and local code requirements must be met when installing a LIFE BREATH clean air furnace. Be sure to consult the proper authorities.
- The Lifebreath clean air furnace is a volume ventilation system. Use the optional Lifebreath bathroom exhaust system kit (99-CAF-BESKIT) if you wish to exhaust from specific locations such as bathroom.
- This manual provides a guideline of good engineering practice in the design, installation and commissioning of Integrated Combo Systems. The guidelines in the manual are designed for residential forced warm air Integrated Combo Systems which utilize domestic water heaters or boilers and the Lifebreath unit. Heating and cooling loads shall be calculated in accordance with recognized Residential Heat Loss and Heat Gain Calculation methods. Duct design shall comply with recognized Residential Air System Design methods. This manual provides worksheets to be used for the purpose of sizing residential water heaters and the combo unit. Manufacturers' instructions for other components, such as the water-heater/boiler, must be followed.



Caution

- All national and local code requirements must be met when installing this unit. Be sure to consult the proper authorities.
- This appliance complies with IAS Canada Inc. Requirement CR95-003, Additional Requirements for Fan Coil Units for use with Potable Water Heaters.
- All piping and components connected to this appliance shall be suitable for use with potable water.
- Toxic chemicals, such as used for boiler treatment, shall not be introduced into the potable water heater system.
- When using this system, and water for space heating is required to be at a higher temperature than for other uses, an anti-scald valve shall be used to ensure water for other uses is reduced in temperature to minimize a scald hazard potential.
- Combining two or more end uses such as space heating and the heating of domestic hot water in a single system has the potential to increase efficiency and reduce overall capital costs. However, the proper design, installation, and commissioning of these systems are critical if these advantages are to be realized.



Warning

- Disconnect the power from the unit before cleaning or servicing.
- Improper installation, adjustment, alteration, service or maintenance can cause property damage, personal injury or loss of life. Installation and service must be performed by a qualified installer or service agency.
- Temperatures greater than 130°F (54°C) pose a serious risk of scalding individuals running domestic hot water for potable use.

Table of Contents

1	Introduction.....	4
2	Operation Heating/Cooling	5
3	The Recovery Core.....	6
4	Combo System Basic Principles.....	7
5	Plumbing	8
6	Drain Connections.....	16
7	Installation	17
8	Weatherhood Installation.....	19
9	Functions and Controls – Standard Motor	20
10	DIP Switch Settings – Standard Motor	21
11	Functions and Controls – ECM.....	22
12	DIP Switch Settings – ECM.....	23
13	Aircom Relays.....	24
14	Timers	25
15	Dehumidistat.....	Error! Bookmark not defined.
16	Balancing the Airflows	26
17	Start-Up Procedure	29
18	Service/Maintenance	30
19	Troubleshooting.....	31
20	Specifications	33
21	System Commissioning.....	36
22	Wiring Diagrams (Standard motor).....	38
23	Wiring Diagrams (ECM)	39
24	Lifebreath Limited Warranty.....	40



1 INTRODUCTION

You will notice that the heated air in your home feels more comfortable than air heated by a conventional furnace. One reason for this is that hydronically heated air is uniform in temperate—no short blasts of hot air or hot and cold temperature spikes. In this regard, the air flowing from your hot air vents will not feel as hot to the touch as air from a conventional furnace.

With a high efficiency, adequately sized natural gas, propane or oil hot water heater/boiler, you will always have plenty of hot water for showers and baths, washing dishes and clothes, and all other normal domestic hot water needs. If there is an unusually high demand for hot water, such as filling a large hot tub, than all you need to do is allow more time for the task so the water heater/boiler can keep up to its job of providing hot water for the heating system as well as other household uses.

Once it is correctly installed, safety will never be an issue with your clean air furnace. No flames, fumes or flue gases to be concerned about. Your domestic hot water heater/boiler now provides the heat source for your furnace.

Overview of the Clean Air Furnace

- (1) Hydronic Coil and Pump Compartment
- (2) Recovery Core and Ventilation Compartment
- (3) Aircom Electronics and Fan Compartment

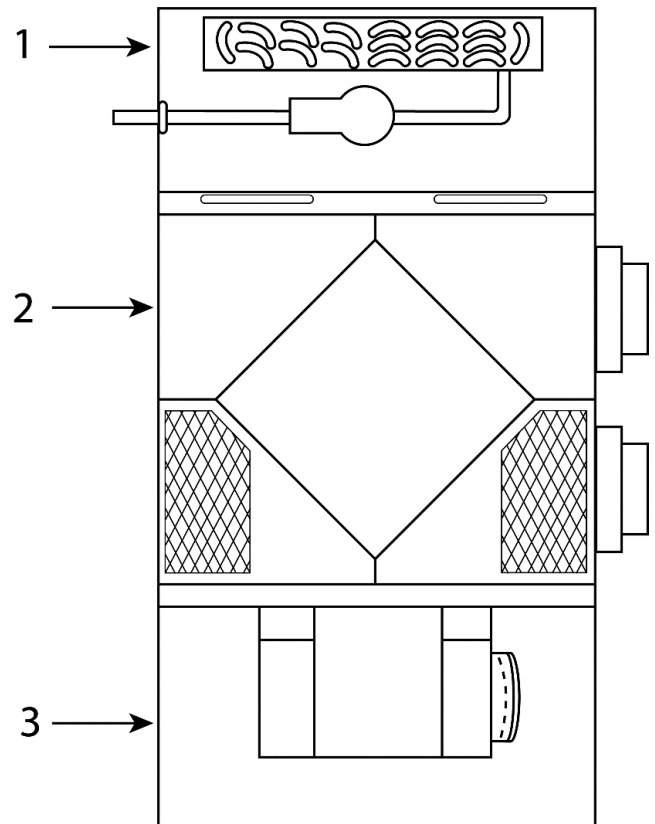

2 OPERATION HEATING/COOLING

When the room thermostat calls for heat, it activates a circulation pump located inside the Clean Air Furnace. This pump delivers hot water from the water heater, through the furnace coil and back to the water tank. Simultaneously, the furnace blower switches on to high speed and will start circulating air across the coil, which picks up heat and delivers it to the rest of your home.

Once the thermostat's temperature is reached the pump will shut off, and the blower will return to its pre-set speed or off.

When the thermostat calls for cooling (evaporator coil and condensing unit required), the furnace blower activates to high speed and the outdoor condenser unit is energized. After the thermostat temperature is reached, the condensing unit will shut off and the blower will return to its preset speed or off.

Ventilation

The heat recovery ventilation (HRV) portion of the clean air furnace is automatic. Once set, a desired amount of fresh air will be drawn into the home while the furnace blower is activated.

To reduce humidity, increased ventilation may be required during heating season. An optional remote dehumidistat can be installed. The dehumidistat will increase the speed of the furnace blower to high and will return to its original setting when humidity levels decrease. Your dehumidistat must be switched off during warmer months. A quality humidifier should be added if you wish to increase winter humidity levels.

Typically, the air flow for ventilation will be set to 50 – 70 cfm, for low speed furnace operation, and 100 – 150 cfm at high speed. The pleated furnace filter should be checked regularly and replaced as needed. The HRV filter should be washed twice a year or more often if needed.

Off Season Circulation Timer

All models are equipped with a circulation timer. It is normal operation for these models to automatically run the circulation pump for a short period of time intermittently.



Note

- When the furnace blower is left running on low speed the air in the home circulates continuously. When the heat is called for the blower will automatically switch to a higher speed. After the required hot air has been delivered the blower will switch back to low speed.

3 THE RECOVERY CORE

HRV – Aluminum Core

A Heat Recovery Ventilator (HRV) is designed to provide fresh air into a building while exhausting an equal amount of stale air. During the winter months, the incoming cold fresh air is warmed by utilizing the heat recovered from the stale air before it is exhausted to the outdoors. During summer months when the indoor space is air conditioned, the HRV will help in cooling the incoming fresh air with the stale air that is being exhausted.

ERV – Enthalpic Paper Core

An Energy Recovery Ventilator (ERV) is designed to provide fresh air into a building while exhausting an equal amount of stale air. An ERV is designed for use in warm humid areas with heavy air conditioning use. The ERV will transfer both sensible and latent heat from the incoming fresh air to the outgoing stale air thereby reducing the load (due to ventilation) on the air conditioning system.

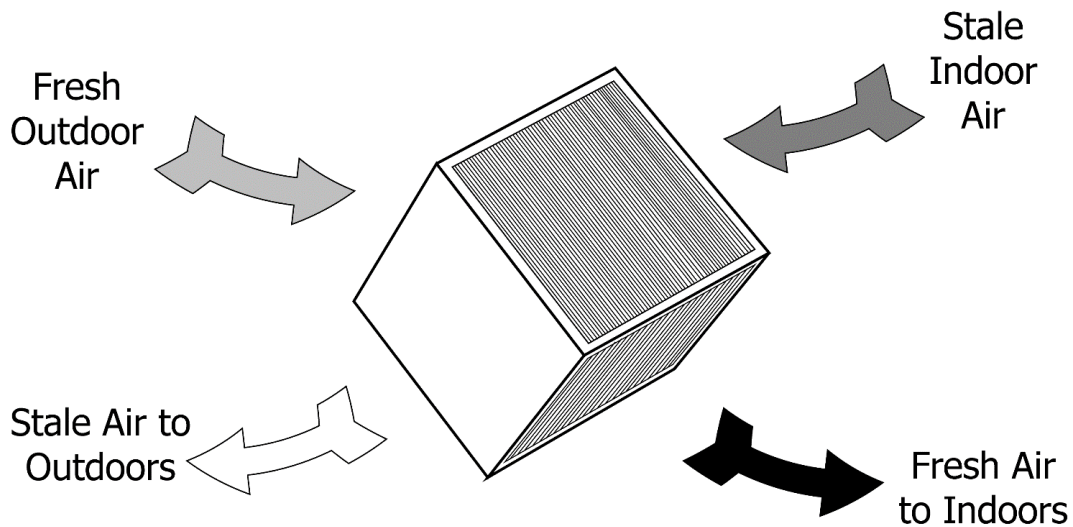

Note

- The ERV Enthalpic Core is not suitable for climates where the outdoor temperature drops below -4° (25°F).

4 COMBO SYSTEM BASIC PRINCIPLES

Open and Closed Systems

Open and Closed systems both deliver hot water and space heating.

Water systems that incorporate a pressure tank (i.e. well systems) are normally Open Systems and most municipal water systems are Closed Systems.

Closed Loop System

A system becomes closed when a Check Valve or a back-flow prevention valve is installed in the cold water piping upstream of the water heater.

A check valve will prevent water being relieved into the cold water system due to pressure created when water is heated in the water heater.

Drain Valve

A drain valve is required to allow the heating loop to be drained for service or repair and to remove air from the heating loop when commissioning a system. The drain valve should be near the low point of the return piping system to be near the water heater. Ball, Globe or Gate Valves are suitable for drain valves.

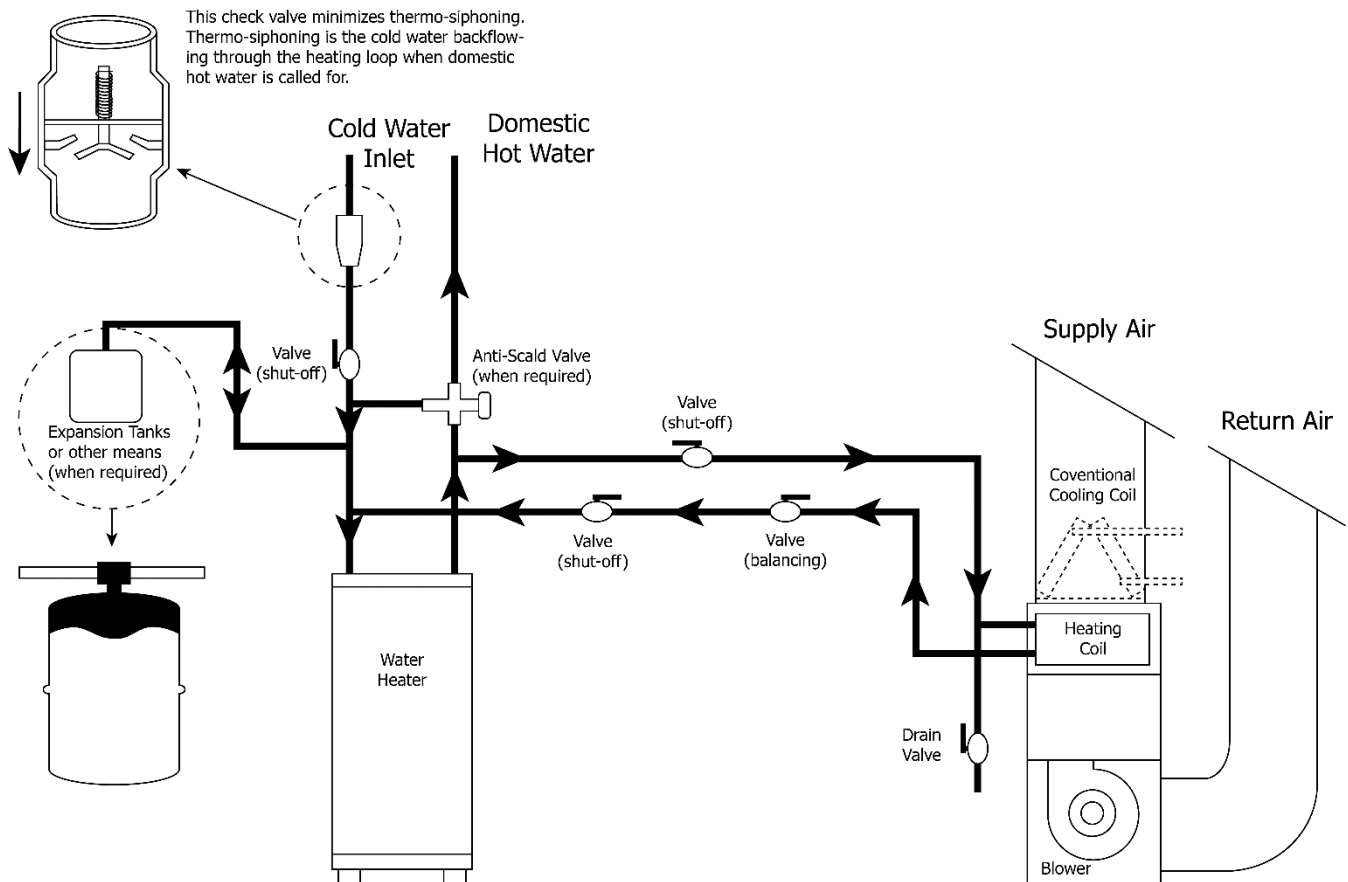

Note

- Check valves should always be installed in a vertical rise with the flow of water shown.
- Refer to local codes, local bylaws and installation manuals supplied with water heater before starting any installation work.

5 PLUMBING

There is an integrated check valve in the coil assembly of the CAF / AH unit.

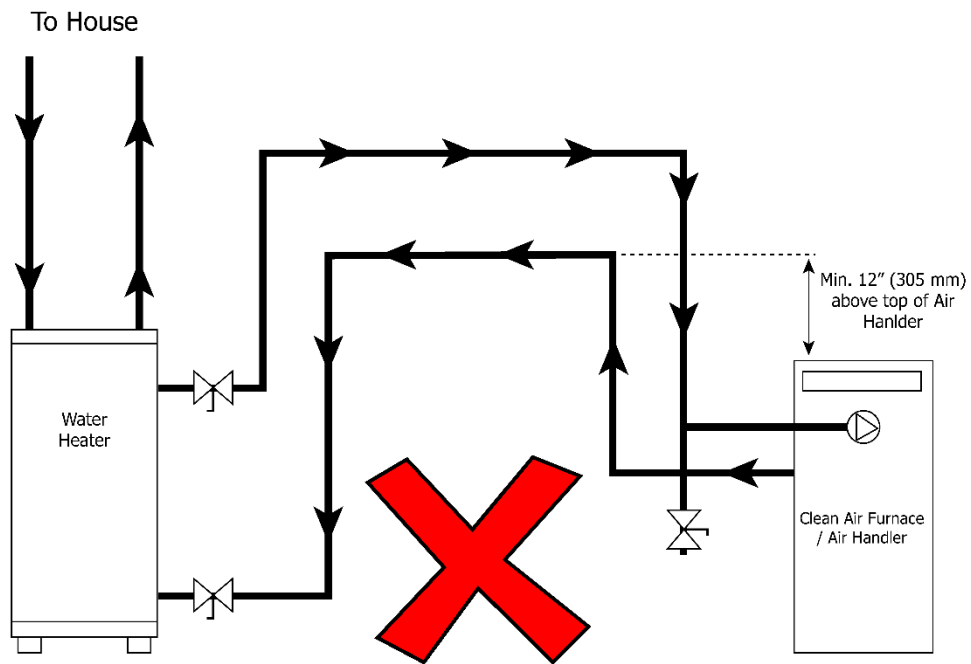
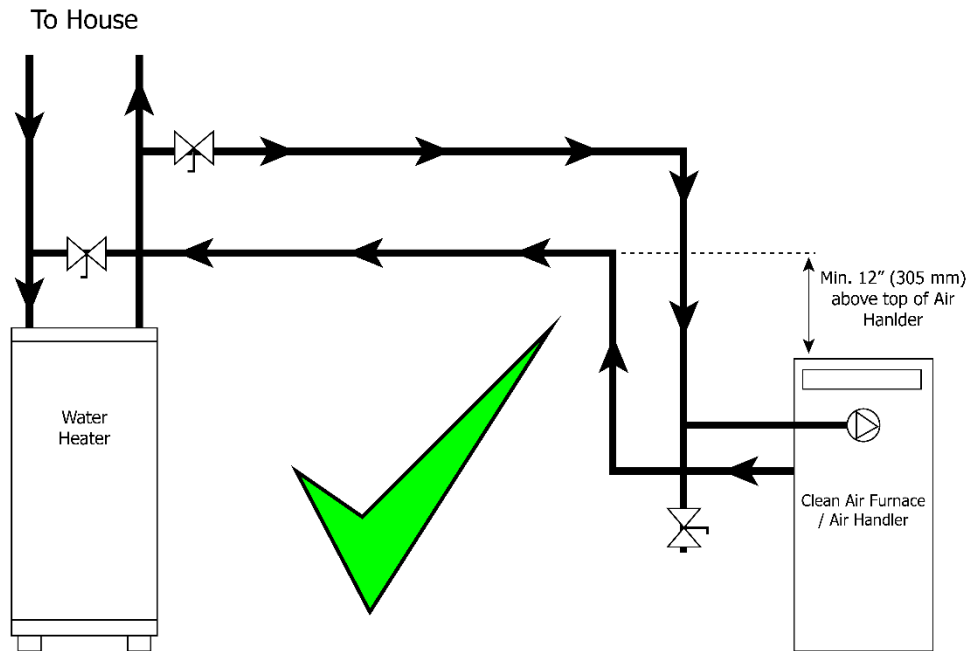

Note

- It should be noted that problems have been observed when using the side tapplings on certain water heaters; therefore, it is strongly recommended to use the top water tapplings as indicated in the above figure to minimize thermal siphoning and related issues.
- Take care during soldering to avoid debris or solder from lodging in the check valve.
- It is critical to follow the piping configuration shown. Maintain a minimum distance of 12" above the CAF/AH. This will minimize thermal siphoning in the combo system.

5 PLUMBING

Expansion Tanks

Expansion tanks are required in addition to a Check Valve for Closed Systems because pressure is created when water is heated in the water heater.

The expansion tank has an air bladder which will contract to relieve pressure in the system. The tank should always be connected to the cold water piping between the water heater shut off valve and the cold water inlet to the water heater.

Anti-Scald Valve

An anti-scald valve is required when the water heater thermostat is set above 140°F (60°C). Also, an anti-scald valve may be required for all installations by the "authority having jurisdiction". The valve is placed in the hot water supply piping from the water heater downstream of the heating loop connection and upstream of any domestic hot water connection.

Time to Scald (1 st degree burns)	
Temperature	Time
120°F (49°C)	8 min.
130°F (54°C)	20 sec.
140°F (60°C)	3 sec.
160°F (71°C)	<1 sec.

The purpose of the valve is to limit the maximum temperature available for domestic hot water by mixing hot water from the water heater with cold water from the municipal supply.

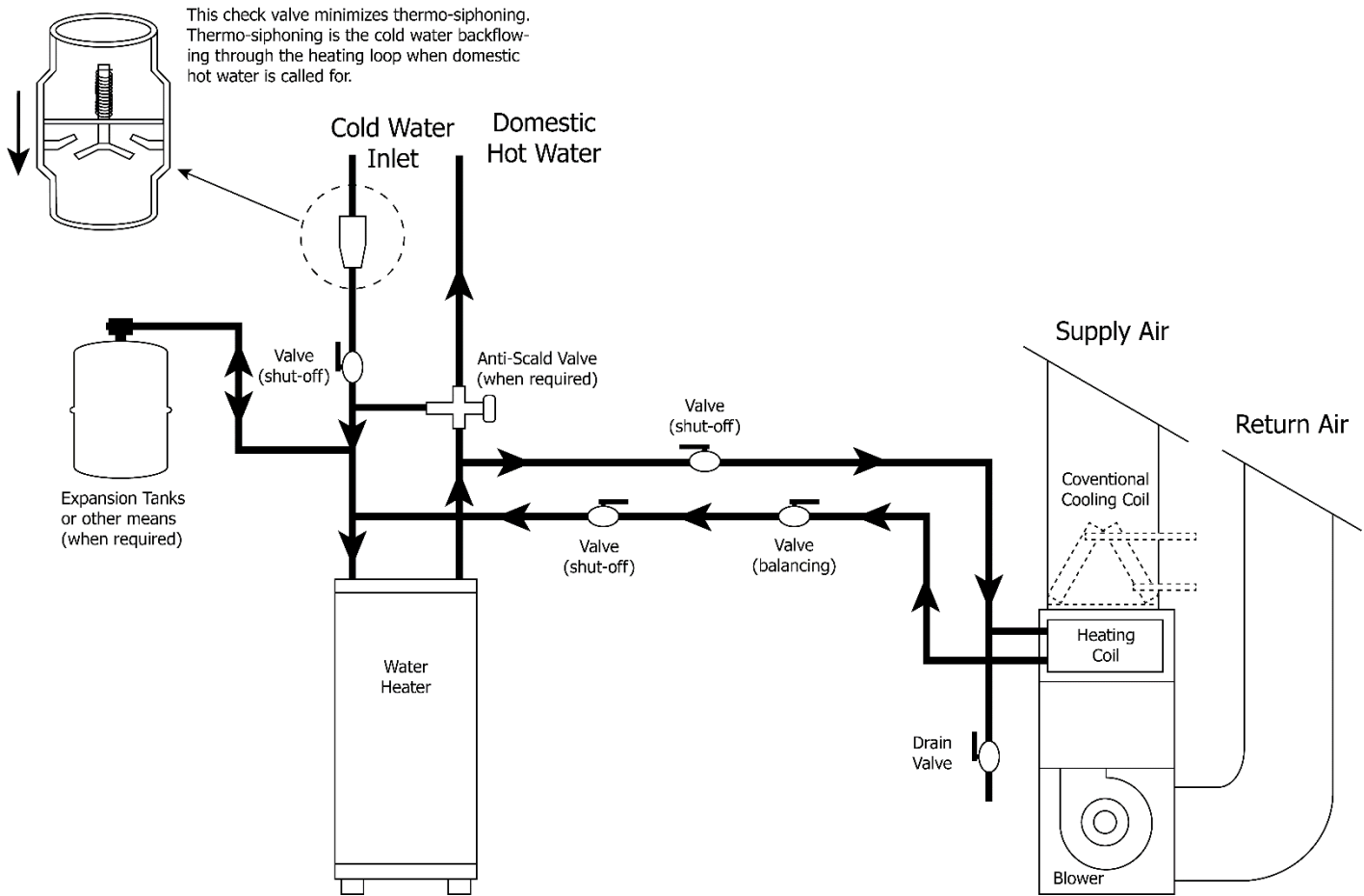

Note

- The Anti-Scald valve must be thermostatically controlled and approved to the ASSE standard No. 1016 and 1017 for use as an anti-scald device.

5 PLUMBING

Valves

- (1) Located on the cold water side of the Heater. This valve can isolate the hot water (domestic and space heating) from the household cold water supply. Every water heater requires this valve regardless of space heating use.
- (2) Located on the hot water supply side of the heating loop, downstream of its connection to the domestic water.
- (3) Located on the return side of the heating loop upstream of its connection to the domestic cold water.

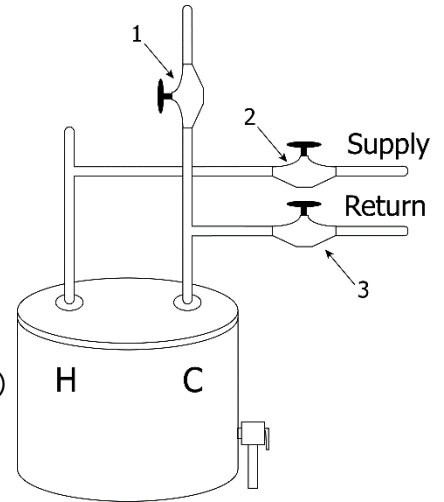

Note: Valves (2) and (3) isolate the heating loop for service or repair.

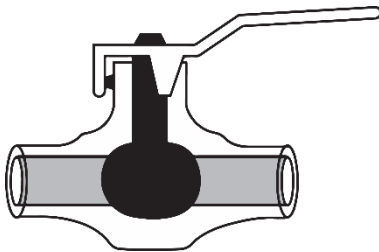

Ball Valve

The Ball Valve can be used as a shut off or drain valve. When in the open position, a full bore ball valve has very little resistance to flow, and these valves tend to be both the least expensive and the least susceptible to seizing over time. Do not use reduced bore ball valves as they are very restrictive to water flow.

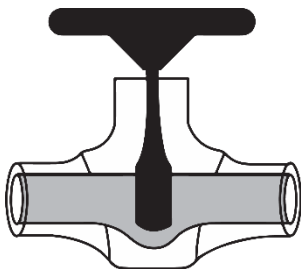

Gate Valve

The Gate Valve can be used as a shut off or drain valve. When in the open position, there is very little resistance to flow. Gate valves tend to be less expensive than other types of valves but are susceptible to chatter (noise) and malfunction with age.

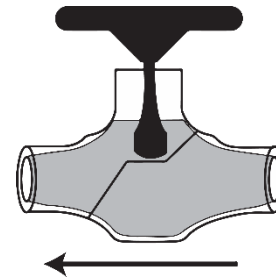

Globe Valve

The Globe valve can be used as a shut off, drain or throttling valve. Even in the open position, the valve is restrictive to flow. It has a much greater equivalent length (resistance.) than the other types of valves.

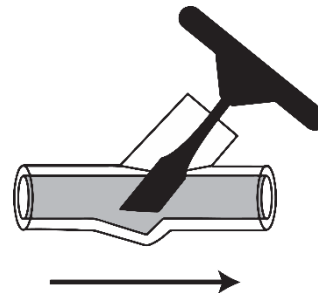

Balancing (Throttling) Valve

The Balancing (Throttling) Valve is used to reduce the water flow rate and thereby increase the water temperature drop. This is done to ensure proper activation of the water heater thermostat.

A Globe Valve could also be used for Balancing (Throttling) but has more resistance than the Balancing Valve.

5 PLUMBING

Call for Space Heating

There are two thermostats controlling every combo system, the water heater thermostat (controlling the hot water temperature) and the room thermostat (controlling the room air temperature). When the room thermostat calls for heat, the circulation pump is activated. Hot water is then drawn from the top of the water heater through the air handler, and then returned to the water heater.

Hot Water Temperature Drop

The water heater thermostat will initiate the water heater as required as long as there is a 20°F (11°C) temperature drop between the hot water supplied to the air handler and the returning water.

A temperature drop of less than 20°F (11°C) can cause the water heater thermostat not to initiate. This will result in a lower hot water supply temperature or poor space heating performance with fluctuating domestic water temperatures.

Call for Domestic Hot Water and Space Heating

When both return water from the space heating loop and new cold water (replacing domestic water being used) enters the water heater, the mixed entering water is cool enough to activate the thermostat quickly. In this situation, the water heater must be capable of satisfying the combined need for domestic hot water and space heating at the same time.

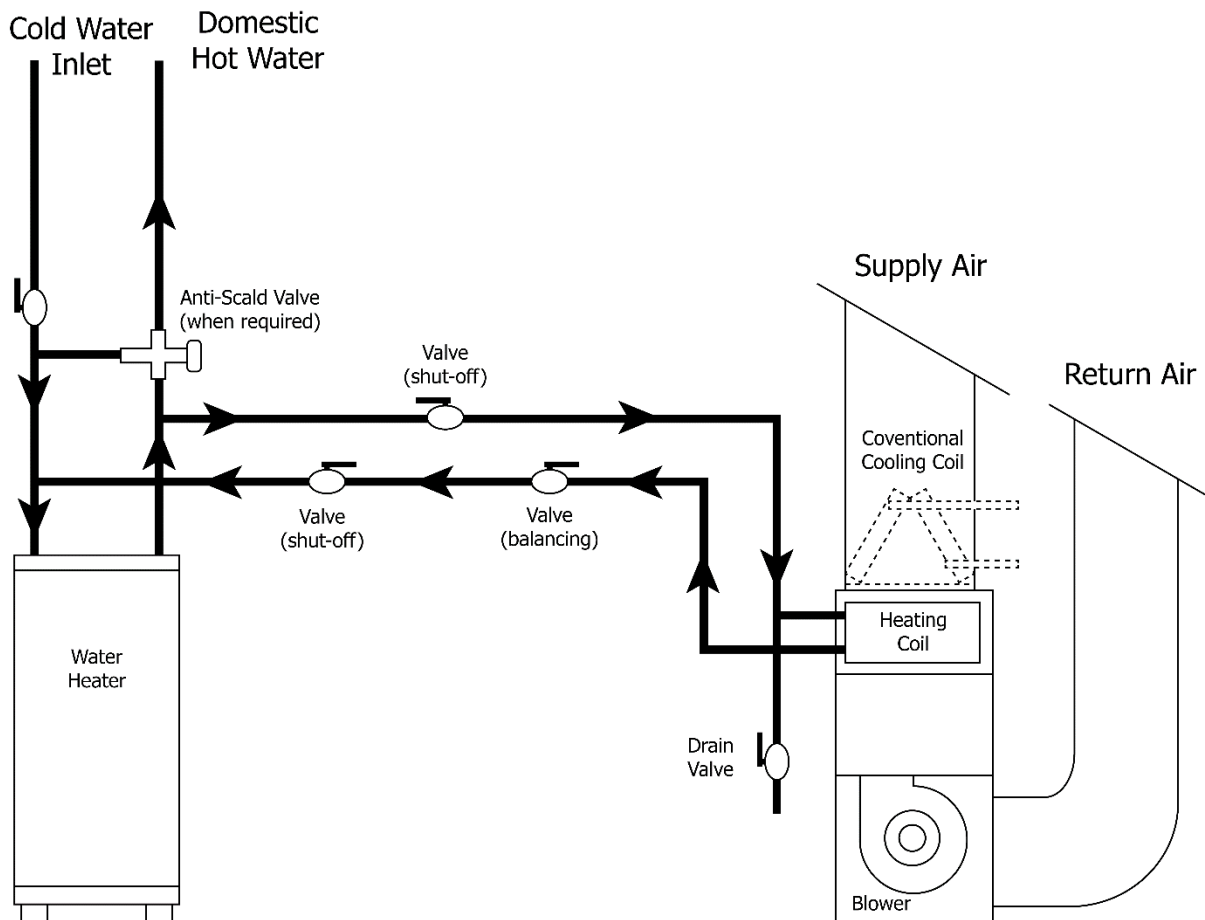

Note

- Plumbing components and system configuration may vary from diagrams portrayed.
- Chemicals (such as boiler system additives) cannot be added to a domestic hot water system.

5 PLUMBING

The pre-assembled, Quick Connect Kit shortens the installation time. It provides an instant, easy assembly of the major plumbing fittings required for a proper CAF/AH installation.

The Quick Connect Kit includes the WATER IN and WATER OUT assemblies. Kits are available in 1/2" and 3/4" sizes. Refer to the CAF/AH specification sheet located in the Operation and Installation Manual to obtain the correct size of water connections for the unit being installed.

Push-fit Fittings instantly make plumbing connections thereby eliminating the need for solder. Be sure to read the Push-fit Fitting Installation Instructions (included with the Quick Connect Fitting Kit) before making any connections.

PART #99-CAF-PKit1/2

The 1/2" assembled kit.

PART #99-CAF-PKit3/4

The 3/4" assembled kit.

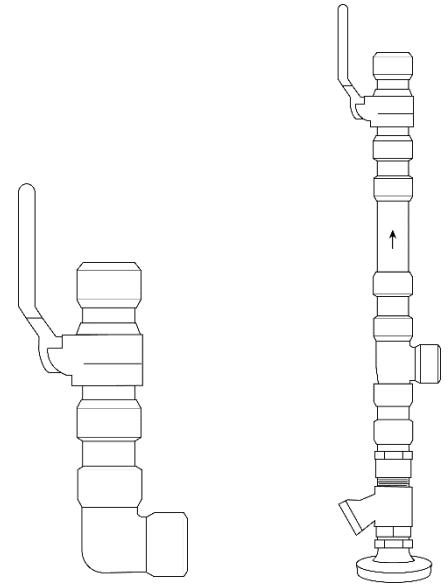

**WATER IN
assembly**

**WATER OUT
assembly**

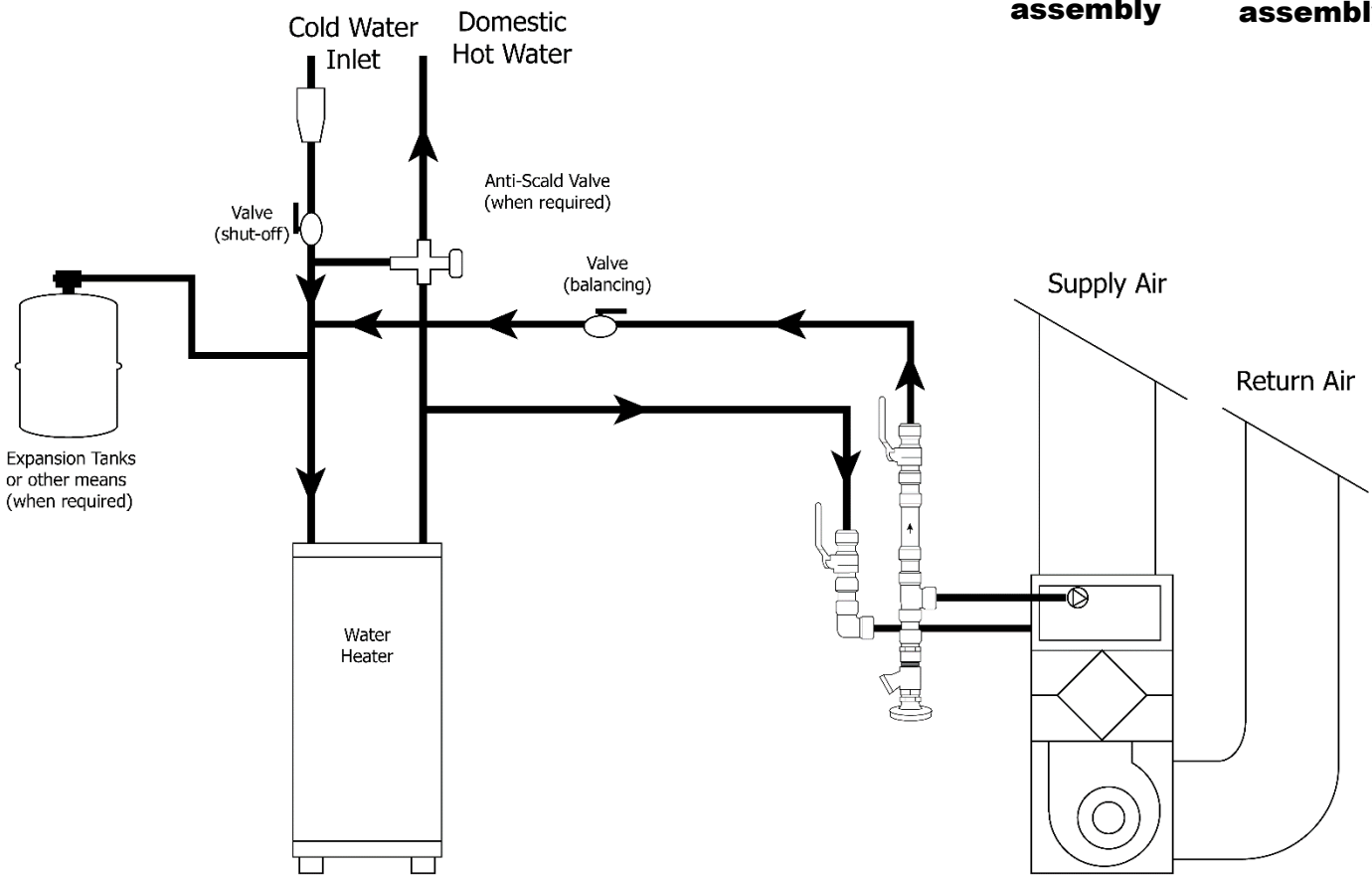

5 PLUMBING

Air System

A circulation fan draws cool house air at approx. 70°F (21°C) from the return ductwork, forces it through the water coil where it is heated, and then distributes it to the various rooms of the house through the supply ductwork.

Water System Pressures

Within the water system of an Integrated Combo system, there are three terms that the designer/installer must understand. These are:

- Head pressure
- Water flow rate
- Pressure drop

Head Pressure

Head pressure is the pressure created by the circulation pump to push water through the piping system. It is this pressure which is used to overcome the resistance to water flow (friction) caused by the water pipe and fittings. It is similar in concept to the external static pressure in an air duct system. Head pressure is measured in feet of water (millimeters of water).

Water Flow Rate

Water flow rate is the amount of water flowing in the system. It is directly related to the head pressure and the resistance to flow. Flow rate is measured in gallons per minute (liters per minute).

Pressure Drop (PD)

Pressure drop (PD) is the reduction in total pressure caused by components added to a piping system such as coils, valves, and fittings. The measurement of pressure drop is the difference in pressure on the inlet side of the component and the outlet side. Pressure drop is measured in feet of water (millimeters of water).

When connecting the water lines for heating loop (air handler) to the domestic water system, the pipes should be connected with a "tee" to the side of a vertical domestic water pipe or the bottom of a horizontal domestic water pipe. This is to help prevent air from entering the heating loop. The connections should be as near as practical to the water heater.

Circulation Pump

The circulation pump is factory installed within the air handler. The water flow rate will vary depending on the pumps performance and the head pressure (resistance) of the complete heating loop system.

The piping and fittings used to connect the water heater and air handler must be sized to handle the volume of hot water required by the air handler within the pressure limitations of the circulation pump. All piping, fittings solders, and fluxes must be acceptable for use with domestic hot water.

Water Pump Performance Specifications

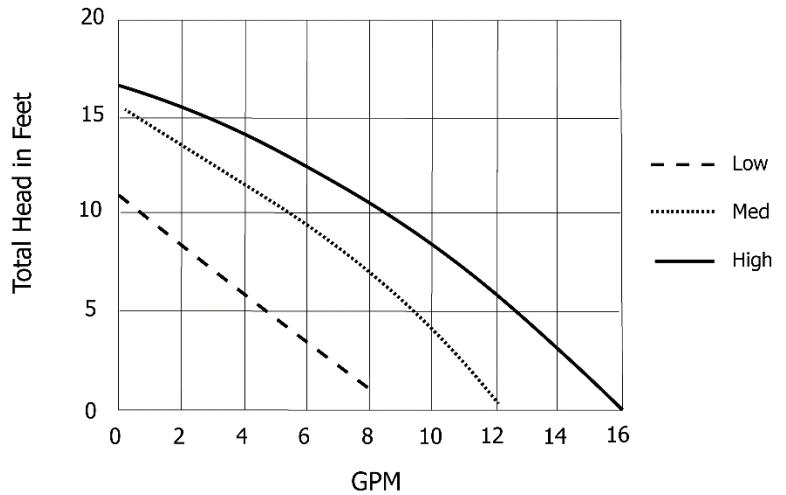

Note

- The vertical height of the heating loop does not impact on the head pressure as the pressure required to push the water up the vertical height is offset by the weight of the water in the vertical drop on the other side of the heating loop.

5 PLUMBING

Air Handler Output Capacity

There are four factors that will significantly affect the heating output of the air handler.

They are:

- Hot water supply temperature (EWT)
- Hot water flow rate (GPM)
- Air Handler return air temperature
- Air Handler air flow rate (CFM) Head Pressure

Hot Water Supply Temperature

The hot water supply temperature is controlled by the water heater thermostat. This is set by the installing contractor to provide the required temperature at the hot water outlet of the water heater.

The hot water supply temperature is typically 140°F (60°C). If this temperature must be increased to achieve higher out-puts from the furnace an anti-scald valve must be used to prevent domestic hot water temperatures above 140°F (60°C). The manufacturer of the Hot water Tank should be consulted for temperatures higher than 140°F (60°C).

It is important that a warning label be placed near the water heater thermostat telling the homeowner not to change the thermostat setting. The label is included with the furnace.

Hot Water Flow Rate

The hot water entering the water coil is the source of heat to the air handler. The effect of changing the amount of water entering the coil is the same as changing the water temperature. As water flow is reduced, the output of the air handler and the air temperature rise will both be lowered.

Air Handler Return Air Temperature

The return air temperature entering the air handler is approx. 60°F (33°C) below the hot water inlet temperature. If the return air temperature entering the air handler is reduced, more heat transfer will occur, and the output of the air handler will increase.

Air Handler Air Flow Rate

The air entering the air handler can only be warmed by the temperature difference between the hot water and the cool air. As the volume (CFM (L/s)) of air is reduced, the amount of heat which can be transferred is also reduced.

Air Handler Temperature Rise

In a fuel fired furnace, the combustion gases can be 1000°F (538°C) above the return air temperature. These units typically have a temperature rise from 50°F (10°C) to 90°F (32°C) and therefore delivers air at the diffuser at 120°F (49°C) to 160°F (71°C).

With an Integrated Combo System, the hot water temperature is approx. 130°F (54°C) which is 60°F (15.5°C) above the return air temperature. These units typically have a temperature rise of 35°F (2°C) to 40°F (4°C) and therefore would deliver air at the diffuser at approximately 105°F (40.5°C) to 110°F (43°C).



Note

- Although the water in the combo system is pressurized by the domestic water system the pump is required to create water flow in the heating loop. The domestic water system applies the same pressure to the supply and return sides of heating loop.

5 PLUMBING

Room Thermostat

The room thermostat controls both the water circulation pump and the air circulation fan. It should be on a centrally located, inside wall away from any source of heat such as diffusers, appliances and direct sunlight.

Energy Saving Room Thermostat

A "set back" thermostat or "smart stat" can be used with a combo system, but care must be taken in the timing of the temperature changes. The timing of morning warm up should be early enough that the desired air temperature has been reached before the people begin to use domestic hot water. The highest demand for space heating is during the morning warm up and the highest demand for domestic hot water is during morning showers. Even if the water heater is properly sized, it may not be able to meet this combined load. Therefore, large setbacks should be avoided.

Design vs. Field Conditions

The factors discussed between design parameters and actual field conditions can impact greatly on output capacity. Therefore, it is important to do a thorough and complete commissioning of the integrated combo system to ensure the design parameters are met.

Piping

The hot water piping between the hot water tank and the Air Handler should be new copper type, and should not be treated with chemicals, sealant or anything else, that will interfere with the purity of the potable water. Only non-lead, low temperature solder is permitted for sealing copper joints.

Where possible the length of pipe should not exceed 200' total equivalent length. Any piping running through unconditioned space must be insulated to prevent heat loss, and possible freezing of the line.

Look inside the furnace and locate the pump. Attach the "Hot Water In" (Supply) to the pipe running to the pump. Attach the "Hot Water Out" (Return) to the pipe running to the coil. Do not reverse these lines, as this will cause the unit to malfunction.

For piping conventional water heaters, connections to and from the Air Handler to the water tank should be made at the point where the pipes leave the tank vertically. A "T" fitting used in each vertical line, with the Air Handler piping connected to the horizontal side of this fitting, will work best in avoiding air locks in the circulation pump of the furnace.



Note

- Remove shipping block from underneath pump and discard.

6 DRAIN CONNECTIONS

The ventilation portion of the Clean Air Furnace has two drain pans for removing condensation, which may occur on the heat recovery core during cold weather. This water should flow into a nearby drain or be taken away by a condensate pump.

Installation:

- (1) Drain Spout
- (2) Drain Pan
- (3) Nut
- (4) Tee Connector
- (5) 1/2 in. Drain Hose
- (6) Drain Line
- (7) Zip tie

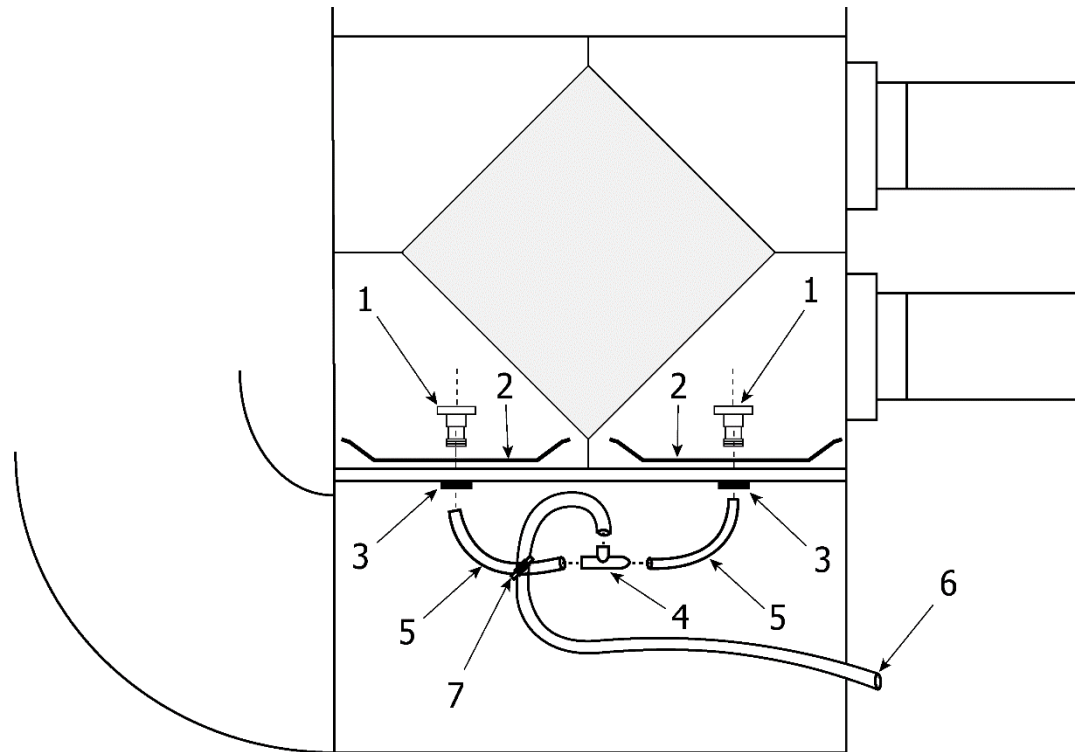

Steps:

1. Insert the drain spout through the hole in the drain pan.
2. Install nut and washer onto the drain spout. Tighten nut.
3. Construct a P-trap using the plastic tee connector.
4. Cut two lengths of 1/2 in. drain hose (not included) and connect the ends to the two drain spouts and the other ends to the plastic tee connector.
5. Position the tee connector to point upward and connect the drain line. Use a zip tie to secure the drain line to one of the 1/2 in. drain hoses.
6. Tape or fasten base to avoid any kinks.
7. Pour a cup of water into the drain pan of the HRV after the drain connection is complete. This creates a water seal which will prevent odours from being drawn up the hose and into the fresh air supply of the HRV.



Caution

- The HRV and all condensate lines must be installed in a space where the temperature is maintained above the freezing point or freeze protection must be provided.
- Drain trap and tubing must be below bottom of door with 1/4 in. per foot downwards slope away from unit.
- A secondary drain pan may be required to protect from condensate leakage.

7 INSTALLATION

Locating the Unit

The clean air furnace is designed to be installed vertically, in a conditioned space, where the surrounding temperature does not fall below 50°F (10°C). Attic installations are not recommended. Typically, the unit is installed in a mechanical area of the basement, or other partitioned mechanical room, elsewhere in the home.

A location close to an outside wall is recommended, as the ventilation supply and exhaust portion will need to be duct-ed to the outside air. Enough clearance around the unit is required for service of the filter, heat recovery core and components. As a rule, this unit should be installed adjacent to the hot water heater. If this is not possible, or if the piping layout is complex, the total head pressure on the pump should be calculated.

Ducting

The duct sizing for the furnace section can be determined using HRAI Residential Air System Design Manual, SMACNA, or any other industry-recognized manuals.

Any ductwork running through unconditioned space must be sealed properly and insulated to prevent heat loss. All local codes must be followed in determining the amount of insulation needed.

The ventilation section consists of two 6 in. (15.2 cm) round ports located on the side of the cabinet, which vent to the outside. Insulated ducting with a vapor barrier such as flex-ducting, or rigid pipe wrapped in pipe sleeve, is required to prevent condensation from occurring on the pipe. Also, the airflow in these lines is designed to be balanced. (See "Balancing Airflows" in this manual, for damper location and procedure).



Note

- All national and local codes relating to this type of equipment must be followed.
- "Combo" units normally deliver air at approximately 110°F (43°C), and therefore may require larger than normal ductwork. When installing the clean air furnace as a replacement unit on a retrofit application, always calculate the size of duct that is there.

7 INSTALLATION

Duct Connections

To accommodate various installations, the clean air furnace has knockouts for the return air plenum and ventilation ducts, on both sides of the cabinet. Slide HRV core out to remove ventilation knockouts.

Figure Callouts

- (1) Remove circular metal knockout
- (2) Remove Styrofoam knockout

- (3) Remove circular metal knockout
- (4) Remove Styrofoam knockout

Ventilation Ports Off Left

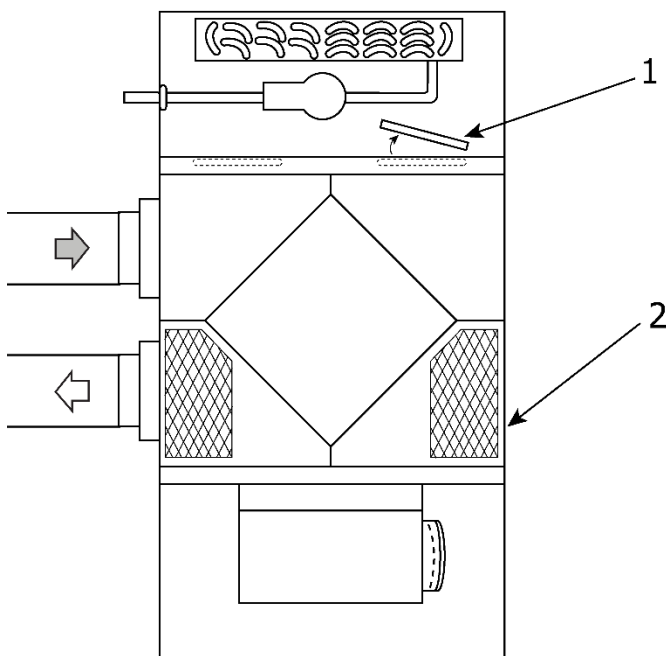

Ventilation Ports Off Right

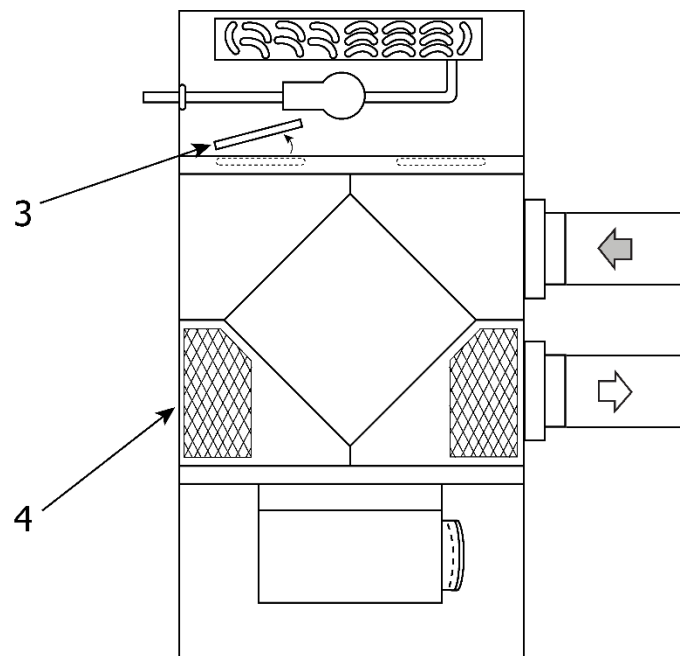

Caution

- Special care and attention should be given to determining which knockouts are to be removed.
- Never install ductwork directly to the cabinet that is smaller than the opening provided.
- Penetrations from sheet metal screws used to fasten the ductwork to the cabinet of the unit should only be placed into the duct flange provided. This is to avoid contact and damage of the heating/air conditioning coils and internal wiring.



Note

- Do not remove the circular knockout when installing the optional Bathroom Exhaust System (99-CAF-BESKIT). Refer to instructions with kit.

8 WEATHERHOOD INSTALLATION

Outside Ducting the Weatherhoods

The ventilation portion of the clean air furnace can be vented off either side of the unit by removing knockouts provided. Once the knockouts are removed, a bead of silicone can be placed on the plastic thermo-collars, to form a seal between the collars and the cabinet. The collars can then be fastened into place with screws. Note the exhaust outlet is always the port on the bottom, and the supply inlet is always the port on the top, both ports should be labeled from the factory as such.

The ductwork from the outside weatherhoods to the unit, is usually flexible ducting, although rigid pipe may be needed if the runs are greater than 10 feet. In either case the pipes (both exhaust and supply and the added fittings) must be insulated, with a complete vapor barrier.

To minimize restriction in airflows the ducting should be short, with as few bends as possible. See diagram below for recommended connection of insulated ducting to outside weatherhoods.

Figure Callouts:

- (1) Thermal Collar
- (2) 12 in. long Galvanized Sleeve
- (3) Exterior Wall
- (4) 1/4 in. (6mm) Mesh Screen

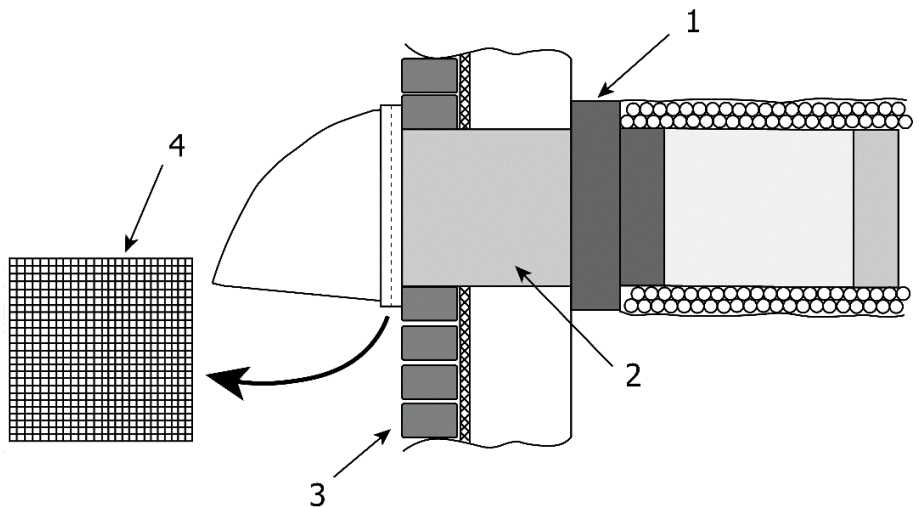

Installation Steps:

1. Thermal collar slides over galvanized sleeve to ensure vapor barrier is 100% sealed to wall plate.
2. Fasten thermal collar to belt.
3. Slide the insulated flexible ducting over galvanized sleeve and fasten it to the thermal collar.
4. Weatherhood is hinged to allow for easy access for cleaning of mesh screen.



Note

- **Weather Hood Requirements:** Check local codes/authority having jurisdiction for acceptance and space requirements for weatherhoods. Do not locate in garage, attic, or crawl space.
 - i) **Intake:** Should be located upstream (if there are prevailing winds) from the exhaust outlet. Not near dryer vents, furnace exhaust, driveways, oil fill pipes, gas meters, or garbage containers.
 - ii) **Exhaust:** Not near a gas meter, electric meter or a walkway where fog or ice could create a hazard.

9 FUNCTIONS AND CONTROLS – STANDARD MOTOR

Basic Functions

- C – Common
- R – 24 volt supply
- W – Medium or High Fan Relay with Circulation Pump (the speed depends on DIP switch #6 setting)
- Y&G – Medium or High Fan Relay (the speed depends on DIP switch #7 setting)
- G – Low Speed Fan Relay
- O – High Speed Fan Relay with Circulation Pump

Aircon Circuit Board

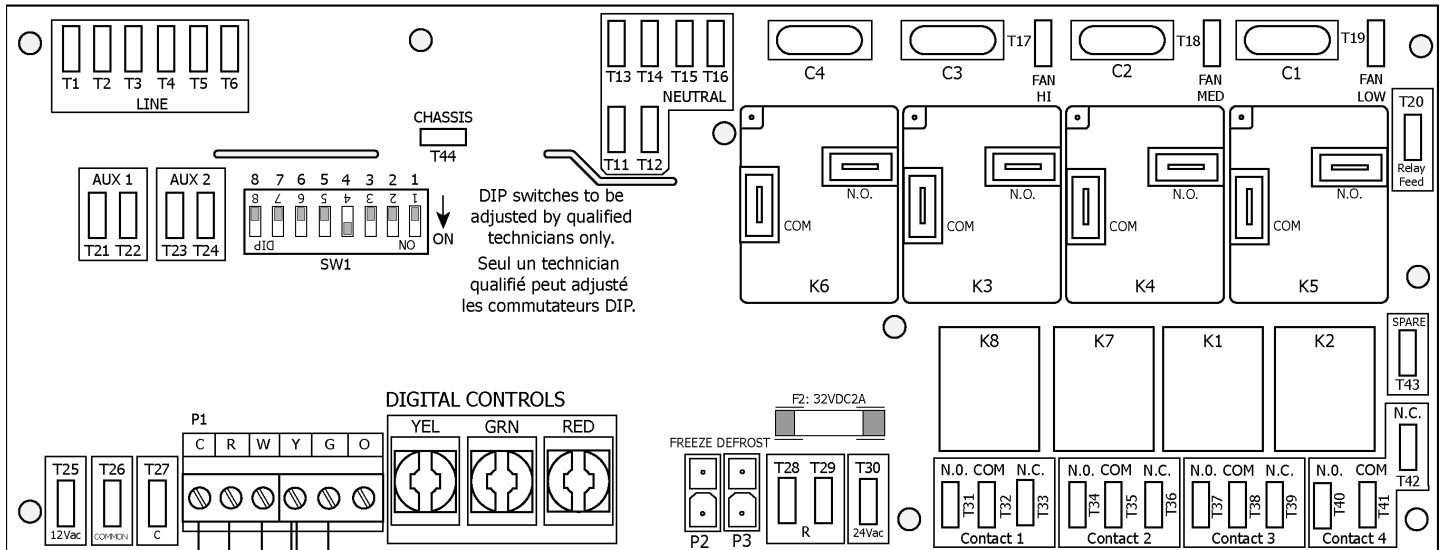

Standard 24 Volt Thermostat Connection

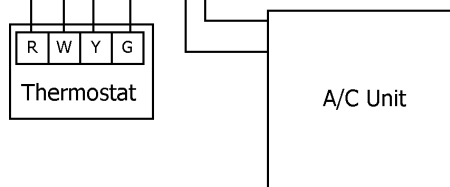

Thermostat Heat Anticipator Settings

- Mechanical Thermostats - start at 0.5 amp and may need to be increased depending upon the residual heat left in the hydronic coil and duct work.
- Electronic
- Thermostats – to be set on electric style heat

Off Season Circulation Timer

Water is periodically circulated throughout the space heating loop during the summer and other periods of infrequent use. The concern is that water which remains stationary in the heating loop during the summer may be less than desirable as domestic hot water when it is returned to the water heater at system startup in the fall.

Warning

- Do not energize the CAF until the plumbing is connected and commissioned. Failure to do so will damage the pump.

10 DIP SWITCH SETTINGS – STANDARD MOTOR

Main board DIP Switch

- DIP Switch #2 to ON will disable the Off Season Circulation Timer
- DIP Switch #6 to ON will select Medium Speed for heating (Factory Setting is OFF for High Speed)
- DIP Switch #7 ON will select Medium Speed for cooling (Factory Setting is OFF for High Speed)

→ ON



Warning

- Do not adjust any other DIP switches than indicated above.

11 FUNCTIONS AND CONTROLS – ECM

Basic Functions

- Thermostat fan switch will control low speed fan operation
- Call for heating – high speed
- Call for cooling – high speed

Aircon Circuit Board

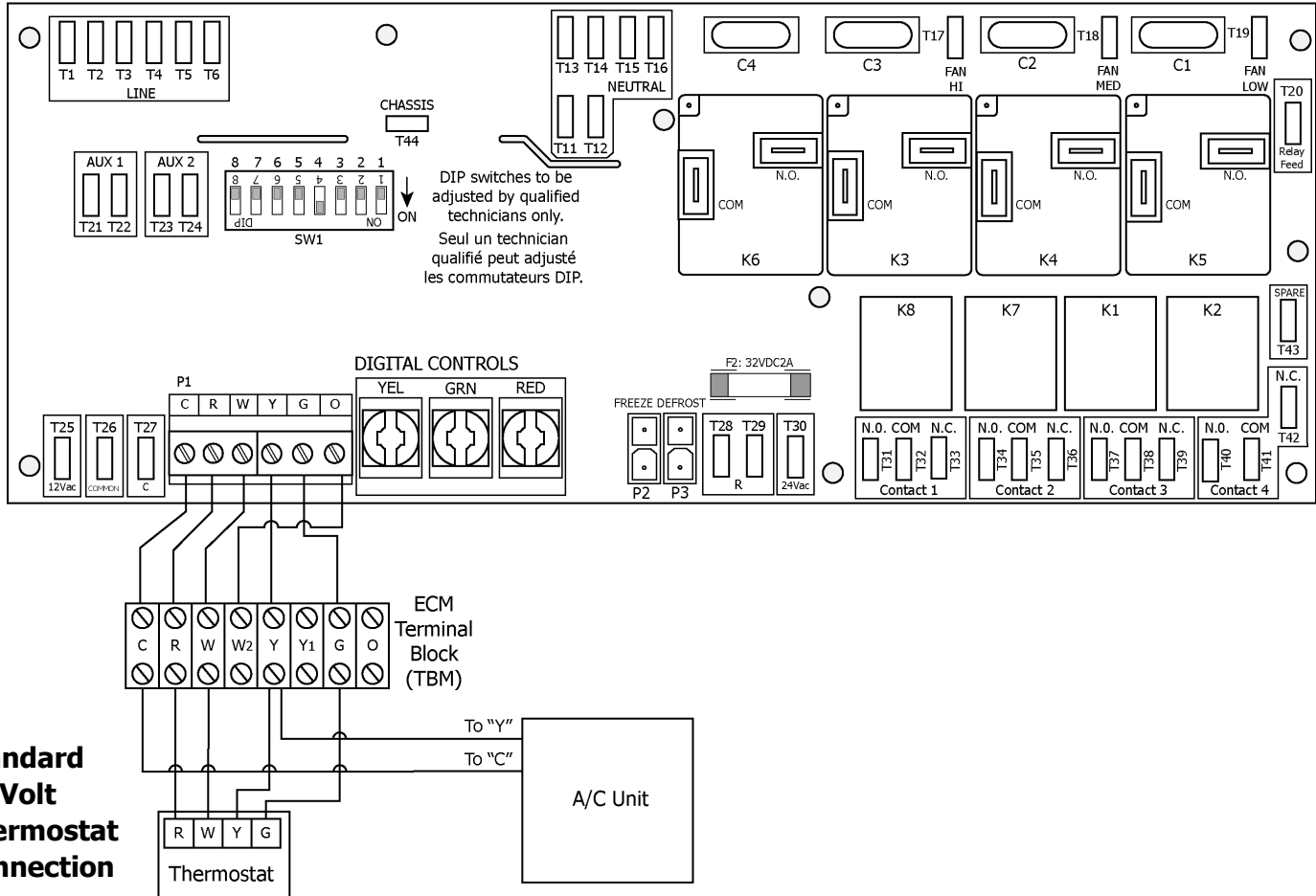

Thermostat Heat Anticipator Settings

- Mechanical Thermostats - start at 0.5 amp and may need to be increased depending upon the residual heat left in the hydronic coil and duct work.
- Electronic
- Thermostats – to be set on electric style heat

Warning

- Do not energize the CAF until the plumbing is connected and commissioned. Failure to do so will damage the pump.

12 DIP SWITCH SETTINGS – ECM

Main Circuit Board DIP Switch

- DIP Switch #2 to ON will disable the Off Season Circulation Timer
- DIP Switch #6 Factory Setting is ON
- DIP Switch #7 Factory Setting is ON

→ ON

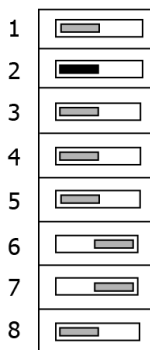

ECM Circuit Board DIP Switch

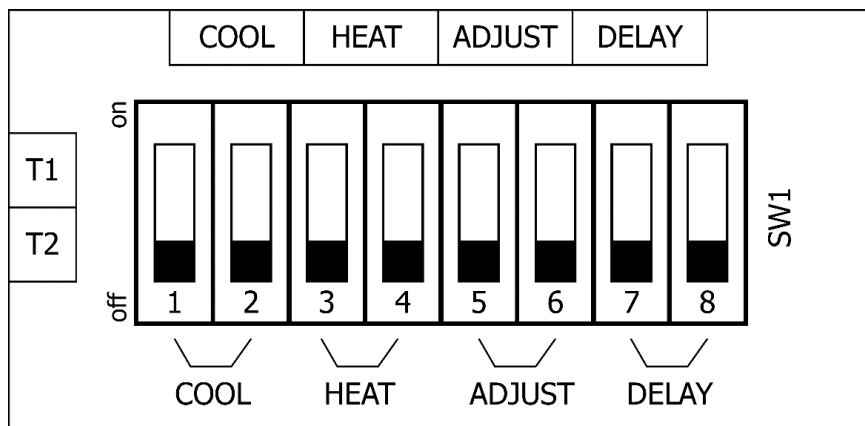

Switch Settings		Fan Speeds
Cool Switches		
1	2	Cool
OFF	OFF	High
ON	OFF	Med. High
OFF	ON	Med. Low
ON	ON	Low

Switch Settings		Fan Speeds
Heat Switches		
3	4	Heat
OFF	OFF	High
ON	OFF	Med. High
OFF	ON	Med. Low
ON	ON	Low

Switch Settings		Fan Speeds	
Adjust Switches		Heat	Cool
5	6		
OFF	OFF	Normal	Normal
ON	OFF	Increase 15%	Increase 15%
OFF	ON	Decrease 15%	Decrease 15%
ON	ON	Normal	Normal

Note: Delay Switches have no function currently.



Warning

- Do not adjust any other DIP switches than indicated above.
- DIP switches #6 and #7 must be ON for the ECM motor to function (factory setting)
- Refer to individual specification pages for Airflow Performance specifications. Above settings correspond to DIP switch settings on the ECM circuit board only. Do not adjust DIP switches on MAIN circuit board.

13 AIRCOM RELAYS

The Aircom circuit board has three available "dry contact" relays. Contact 3 is not available.

Contact 1

- This relay is a dry contact (no power supplied from board). The relay switches upon a call for heat.
- This relay can be used to switch the heat demand signal for boiler operation.
- Power (if required) must be supplied to common from an external source.
- Max. Voltage - 120 volts
- Max. Amperage - 10 amps
- Maximum 115V 10 amp resistive load.

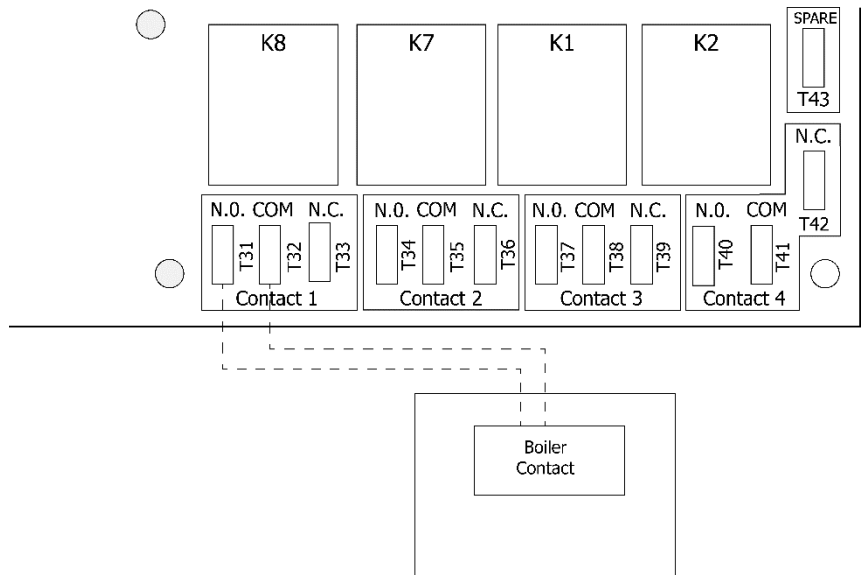

Contact 2 and 4

- These relays are dry contacts (no power supplied from board). The relays switch whenever the CAF blower motor is operating.
- These relays can be used to interlock Humidifiers, Air Cleaning Equipment, etc.
- Power (if required) must be supplied to common from an external source.
- Max. Voltage - 120 volts
- Max. Amperage - 10 amps

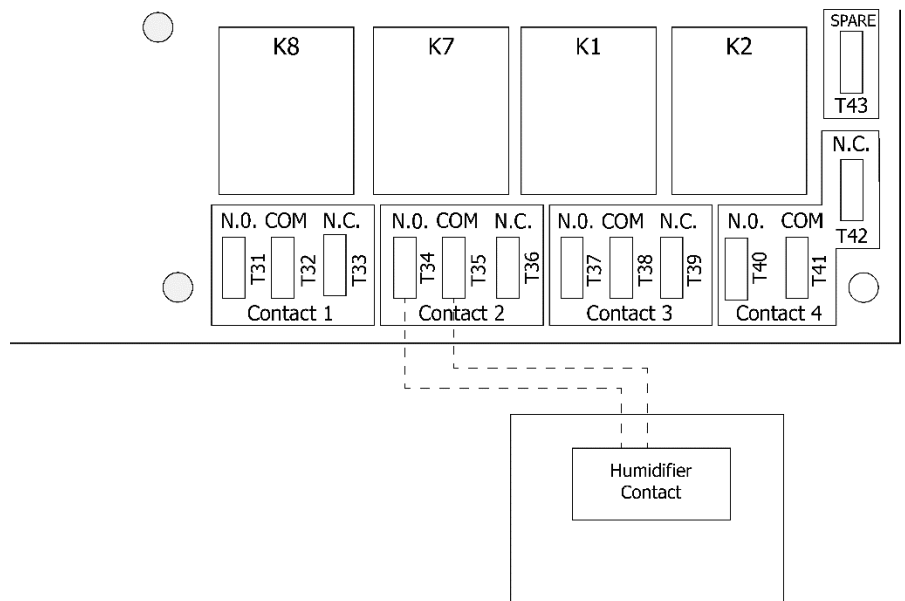

14 TIMERS

20/40/60 Minute Timer (99-DET01) Operation:

- (1) Select Button
- (2) 20/40/60 minute status lights

Press the Select Button on the timer to initiate high speed ventilation for 20, 40, or 60 minutes. The 20/40/60 minute status lights indicate high speed operation.

Lockout mode is useful if you wish to disable the timer:

- Enable Lockout Mode by holding the Select Button for 5 seconds.
- Disable Lockout Mode by holding the Select Button for 5 seconds.

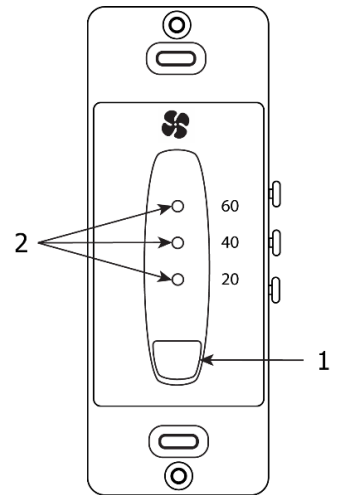

20/40/60 Minute Timer (99-DET01) Installation:

Connect the wires from the Y, R, and G terminals on the timer to the YEL, RED, and GRN terminals on the circuit board as shown.

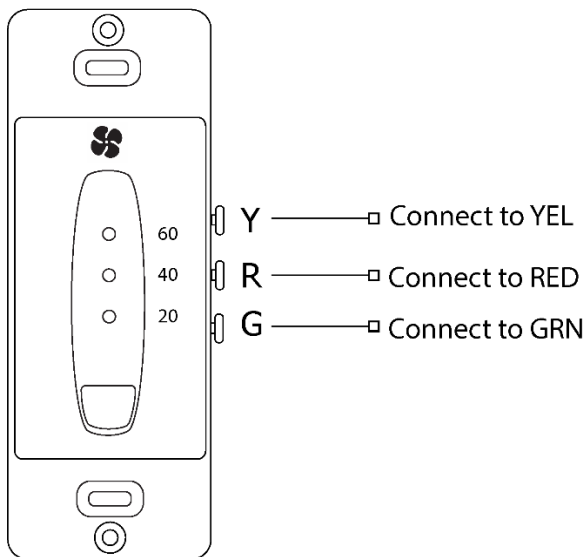

Circuit Board

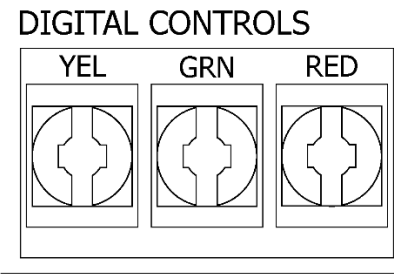

⚠ Note

- Timers mount in standard 2" x 4" electrical boxes.
- Wire multiple timers individually back to the unit.
- Use 3 wire; 20-gauge wire (minimum)

15 BALANCING THE AIRFLOWS

It is necessary to have balanced air flows in an HRV. The volume of air brought in from the outside must equal the volume of air exhausted by the unit. If the air flows are not properly balanced, then;

- The HRV may not operate at its maximum efficiency
- A negative or positive air pressure may occur in the building
- The unit may not defrost properly
- Failure to balance HRV properly may void warranty

Read the Application Warning on the front of this manual!

Prior to balancing, ensure that:

1. All sealing of the ductwork system has been completed.
2. All the HRV's components are in place and functioning properly.
3. Balancing dampers are fully open.
4. Unit is on HIGH speed.
5. Air flows in branch lines to specific areas of the house should be adjusted first prior to balancing the unit. A smoke pencil used at the grilles is a good indicator of each branch line's relative air flow.
6. After taking readings of both the stale air to the HRV duct and fresh air to the house duct, the duct with the lower CFM ([L/s] velocity) reading should be left alone, while the duct with the higher reading should be adjusted back to match the lower reading.
7. Return unit to appropriate fan speed for normal operation

Balancing Procedure

The following is a method of field balancing an HRV using a Pitot tube, advantageous in situations when flow stations are not installed in the ductwork. Procedure should be performed with the HRV on high speed.

1. The first step is to operate **all** mechanical systems on high speed, which have an influence on the ventilation system, i.e. the HRV itself and the forced air furnace or air handler if applicable. This will provide the maximum pressure that the HRV will need to overcome and allow for a more accurate balance of the unit.
2. Drill a small hole in the duct (about 3/16"), three feet downstream of any elbows or bends, and one foot upstream of any elbows or bends. These are recommended distances, but the actual installation may limit the amount of straight duct.
3. The Pitot tube should be connected to a manometer capable of reading 3 digits of resolution. The tube coming out of the top of the pitot is connected to the high pressure side of the gauge. The tube coming out of the side of the pitot is connected to the low pressure or reference side of the gauge. Insert the Pitot tube into the duct; pointing the tip into the airflow.
4. For general balancing it is enough to move the pitot tube around in the duct and take an average or typical reading. Repeat this procedure in the other (supply or return) duct.
5. Determine which duct has the highest airflow (highest reading on the manometer).
6. Adjust the higher airflow adjusting the field supplied damper. The flows should now be balanced. Actual airflow can be determined from the gauge reading. The value read on the gauge is called the velocity pressure. The Pitot tube comes with a chart that will give the air flow velocity based on the velocity pressure indicated by the gauge. This velocity will be in either feet per minute or meters per second. To determine the actual airflow, the velocity is multiplied by the cross-sectional area of the duct being measured.



Attention

- Continuous, excessive, positive pressure may drive moist indoor air into the external walls of the building. Once inside the external walls, moist air may condense (in cold weather) and degrade structural components or cause locks to freeze.
- Continuous, excessive, negative pressure may have several undesirable effects. In some geographic locations, soil gases such as methane and radon gas may be drawn into the home through basement or ground contact areas and may also cause the backdrafting of vented combustion equipment.

16 BALANCING THE AIRFLOWS

Example:

This is an example for determining the airflow in a 6 in. (0.5 ft) duct.

- The Pitot tube reading was 0.025 inches of water. From the chart, this is 640 ft/min.

The 6 in. (0.5 ft) duct has a cross sectional area of:

$$A = \pi r^2 = [\pi d^2] / 4$$

$$A = [3.14 \times (0.5 \text{ ft})^2] / 4$$

$$A = 0.2 \text{ ft}^2$$

The airflow is then: (640 ft./min.) x (0.2 ft²) = 128 cfm

For your convenience, the cross-sectional areas of some common duct sizes are listed below:

DUCT. DIAM. (inches)	CROSS SECTION AREA (sq. ft.)
5 (127 mm)	0.14
6 (152 mm)	0.20
7 (178 mm)	0.27

The accuracy of the air flow reading will be affected by how close to any elbows or bends the readings are taken. Accuracy can be increased by taking an average of multiple readings as outlined in the literature supplied with the Pitot tube.

Note: Duct connections may vary, depending on model.

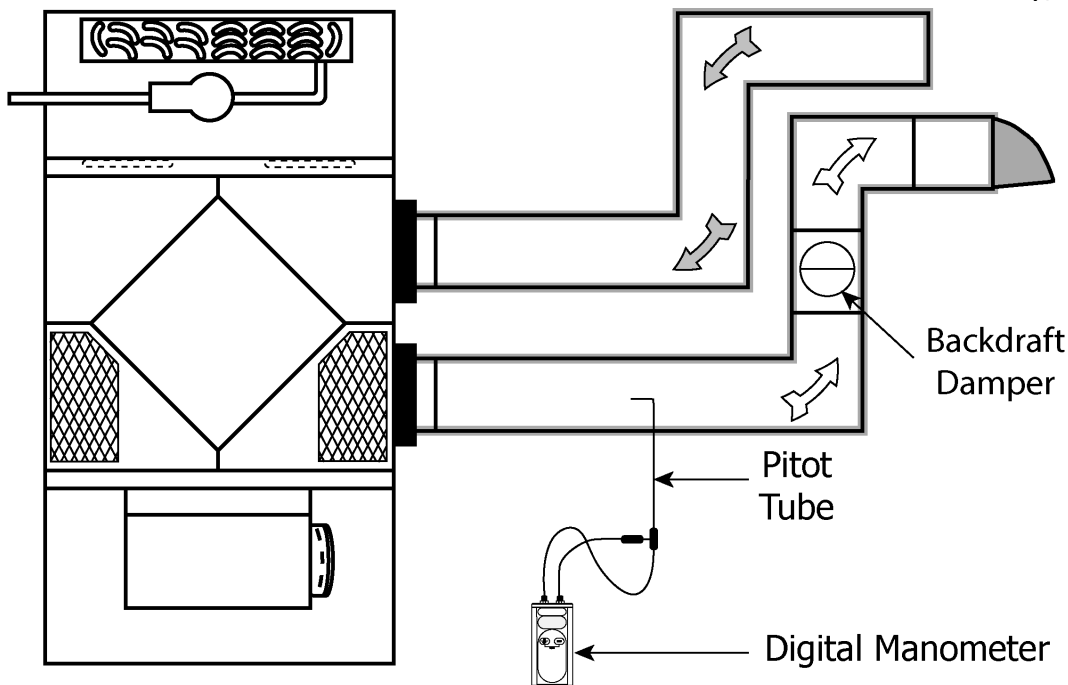

Note: For best results keep Pitot tube well away from dampers

16 BALANCING THE AIRFLOWS

Balancing Collar Instructions

Hard/Rigid Ducting

- Push and turn with slotted screwdriver. Damper automatically locks when pressure released.

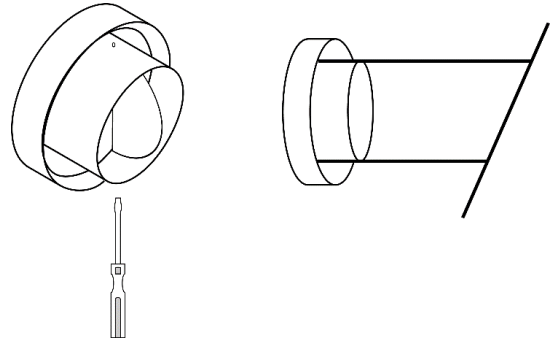

Insulated flexible ducting

- When connecting ductwork to the collar, take note where screws are located. Screws should be located no further than 1/2 (12.7 mm) from outside edge of collar, so as not to impede operation of the damper.

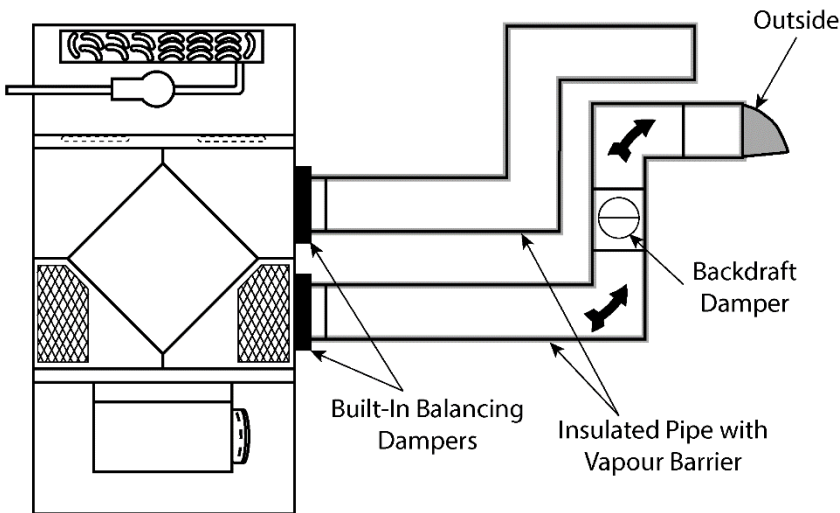
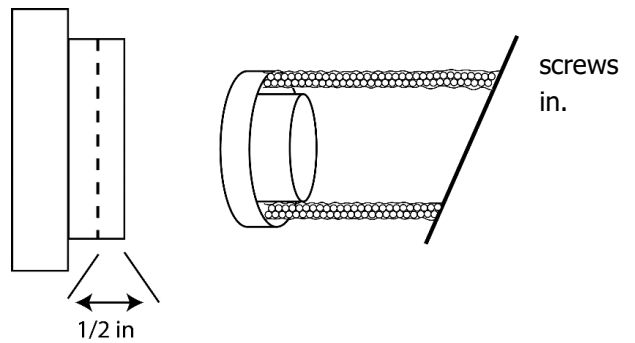

Backdraft Damper

The back draft damper (not included) can be located anywhere in a vertical rise of the exhaust duct.

Warning

- A Backdraft damper is required in the exhaust air duct to prevent cold air from entering the unit when the Clean Air Furnace is not running.

17 START-UP PROCEDURE

For any appliance to work properly it must be set up and tested by a knowledgeable technician.

The following conditions must be met prior to start-up

1. Ensure that connecting water lines are purged and free of debris.
2. Caution: solder or other debris may cause the furnace pump or check valve to malfunction.
3. Blower wheel rotates freely inside its housing.
4. Wiring connections are tight.
5. All duct and pipe connections are sealed.
6. Check that styrene block is removed from under pump.
7. Front access door is on tight.
8. Fan speed selection:
 - a) Heating/Cooling - factory setting is at high speed and can be changed in the electrical box to medium-high or medium if required.
 - b) Ventilation – low speed is controlled by the Thermostat Fan switch.

Once the necessary connections have been made, follow the procedure:

Step 1. Close shut-off valves separating the Clean Air Furnace from the water heater.

Step 2. Set up water heater according to manufacturer's instructions.

Step 3. Purge air from unit. To do so, open the supply shut-off valve to the furnace. Attach a garden hose to drain valve and drain water until you get a continuous flow. Close the drain valve and purge the pump. To purge the air from the pump, turn the large screw on the face of the pump counterclockwise until water leaks out, then tighten. Open the supply shut-off valve.

Step 4. Turn on power supply to Clean Air Furnace. **Caution:** *Blower may start to operate at low speed.*

Step 5. Switch the room thermostat to heat. The thermostat should be set higher than the current room temperature in order to energize the pump and commence the heating cycle. (If the pump does not start, or the Clean Air Furnace is not producing heat, refer to the Troubleshooting Section in this manual.

Step 6. Set room thermostat at desired temperature setting.

18 SERVICE/MAINTENANCE

A dedicated maintenance program will prolong the life of the equipment and maintain its optimum performance.

We recommend at least two full inspections and cleanings per year under normal operating conditions, and more if circumstances warrant it (i.e. situations of heavy smoke may require servicing every one to two months).

Figure Callouts:

- (1) Hot Water Supply/Return
- (2) Hot Water Circulation Pump
- (3) Filters
- (4) PSC type hi-efficiency motor
- (5) Heat recovery ventilator core
- (6) Ultra-efficient heating coil

Airflow:

- ⇨ Stale Air to Outside
- ⇨ Fresh Air from Outside
- ⇨ Stale Air from Inside
- ⇨ Fresh Air to Inside

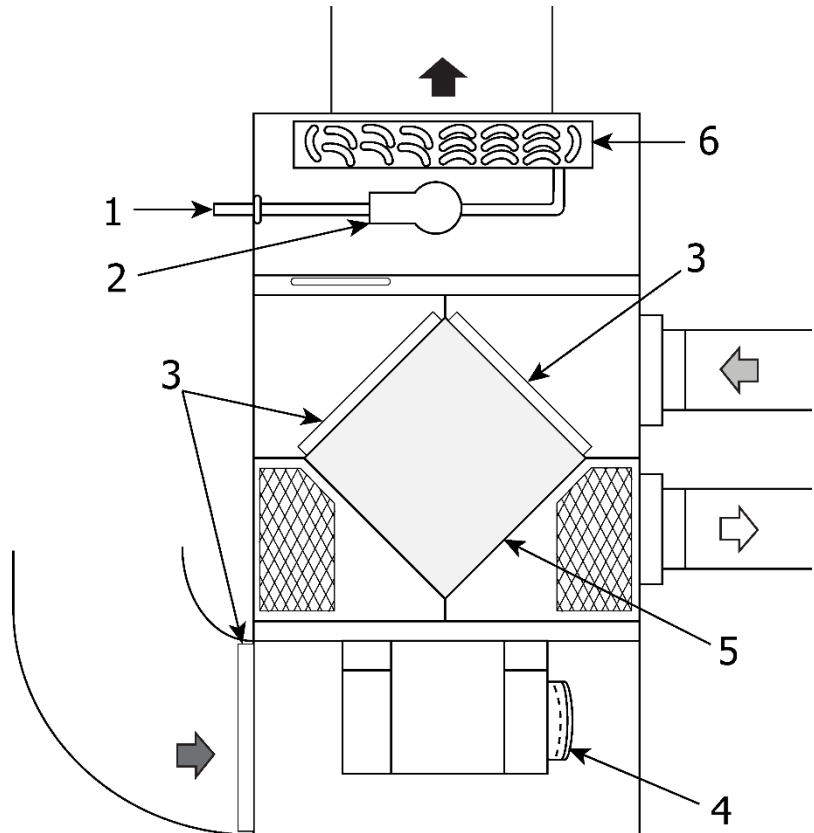

Service Should Include:

- Cleaning of screens protecting outside hoods
- Cleaning of the HRV (aluminum) core
- Inspect filters and replace as necessary
- Wipe down drain pans and inside of cabinet using a mild disinfectant
- Ensure condensate drain has free flow of moisture
- Inspect operation of blowers and electrical panel
- Confirm operation

Clean Core Twice a Year

- a) Open access door.
- b) Carefully grip ends of core and pull evenly outward. Core may be snug but will slide out of the "H" channel.
- c) Once removed from the cabinet, remove the foam filters.
- d) Wash the core in warm soapy water (do not use dishwasher).
- e) Filters can be rinsed with cold water or a combination of mild soap and water. Do not wring out or clean in dishwasher.
- f) Install the clean filters.
- g) Install the clean core.

19 TROUBLESHOOTING

Refer to the following table for troubleshooting your Clean Air Furnace.

Table 5.1 – Troubleshooting Procedures

SYMPTOM	CAUSE	SOLUTION
Lack of Heat	<ul style="list-style-type: none"> Several factors may contribute to this problem, follow the steps in the Solution column. 	<ol style="list-style-type: none"> Check that the room thermostat is set to the desired temperature. Confirm the units have power and the shut-off valves are open. Ensure there is power to the unit and that the pump is working. If the pump is not working properly it may be stuck. <ul style="list-style-type: none"> Disconnect power and remove screw in center face of the pump. Using a screwdriver, turn the pump shaft several times to free it from sticking. Replace center-screw and re-connect power. If pump still fails to start, it may require replacement. Confirm that the hot water heater is working, and that hot water is entering the Clean Air Furnace Verify that the airflow in and out of the system matches designed specs. If airflow is low, check for blockage in the filter or some other obstruction. Make sure your water heater is sized large enough for heat load of house and for domestic hot water use. Air may still be in the water lines. If so, re-purge the system according to the startup procedure. Confirm that the inlet and outlet pipe connections are not reversed. Ensure that there are no other restrictions in the water lines, such as faulty valves, or debris.
Pump is noisy	<ul style="list-style-type: none"> Pumps can become noisy when air remaining in the lines interfere with their operation. 	<ul style="list-style-type: none"> Re-purge the system as indicated in the Start-Up Procedure.
HRV core freezes up	<ul style="list-style-type: none"> HRV airflows are improperly balanced 	<ol style="list-style-type: none"> Make sure that the supply and exhaust lines are balanced according to the "Balancing Procedure" in this manual. If out of balance, ensure that the balance dampers have not been moved and that there are no obstructions in the outside hoods.

19 TROUBLESHOOTING

Refer to the following table for troubleshooting your Clean Air Furnace.

Table 5.1 – Troubleshooting Procedures (cont.)

SYMPTOM	CAUSE	SOLUTION
During cooling cycle, hot water circulates through the coil	<ul style="list-style-type: none"> If the check valve inside the cabinet is stuck in the open position, hot water may infiltrate the heating coil. This occurs when the hot pipes are not capped-off during installation or service and foreign debris enters the piping. This debris can settle under the check valve seat and permit hot water to flow into the coil. 	<ul style="list-style-type: none"> Repeatedly flush the heating loop until it is clean.
Water sits in drain pans	<ul style="list-style-type: none"> Several factors may contribute to this problem, follow the steps in the Solution column. 	<ol style="list-style-type: none"> Check drain pans or lines for plugs Confirm that the HRV core is installed according to manufacturer's recommendations. Check the drain lines for kinks. Make sure that the O-ring in the drain nozzles sit flat. Ensure the drain line has enough "fall" to it.
Condensation/ice forming inside ventilation ducts	<ul style="list-style-type: none"> A rip in the vapor barrier or poorly sealed joints may cause condensation or ice to form on the ducting 	<ul style="list-style-type: none"> Replace the entire line.

20 SPECIFICATIONS

S4A-24 Coil Output Chart (1000's of BTUH)

CFM @ 0.5" w.g.	890	40.7	47.7	54.8	61.9	69.0	76.2
	790	38.0	44.5	51.0	57.6	64.3	70.9
	740	36.5	42.7	49.0	55.3	61.7	68.0
	660	33.8	39.6	45.5	51.3	57.2	63.0
CFM @ 0.25" w.g.	1030	44.0	51.7	59.3	67.0	74.8	82.5
	900	41.0	48.0	55.1	62.3	69.4	76.6
	825	38.9	46.7	52.4	59.2	66.0	72.8
	740	36.5	42.7	49.0	55.3	61.7	68.0
Water Temp. (°F)		130	140	150	160	170	180
3 GPM							

CFM @ 0.5" w.g.	890	43.8	51.3	58.9	66.5	74.1	81.7
	790	40.5	47.4	54.4	61.3	68.3	75.4
	740	38.7	45.3	51.9	58.6	65.3	72.0
	660	35.6	41.7	47.8	53.9	60.0	66.2
CFM @ 0.25" w.g.	1030	48.0	56.2	64.5	72.8	81.2	89.6
	900	44.1	51.7	59.3	66.9	74.6	82.3
	825	41.7	48.8	56.0	63.2	70.4	77.6
	740	38.7	45.5	51.9	58.6	65.3	72.0
Water Temp. (°F)		130	140	150	160	170	180
4 GPM							

CFM @ 0.5" w.g.	890	45.7	53.6	61.4	69.3	77.2	85.1
	790	42.0	49.2	64.4	63.6	70.8	78.0
	740	40.0	46.8	53.7	60.5	67.4	74.3
	660	36.7	42.9	49.2	55.4	61.7	68.0
CFM @ 0.25" w.g.	1030	50.5	59.1	67.8	76.5	85.3	94.1
	900	46.1	54.0	61.9	69.8	77.8	85.8
	825	43.5	50.9	58.3	65.8	73.3	80.8
	740	40.0	46.9	53.7	60.5	67.4	74.3
Water Temp. (°F)		130	140	150	160	170	180
5 GPM							

CAF-U-S4A-24-P16/E16	
Voltage	120 Vac 60 HZ
HP	1/3
Amps (total)	8
Water Connections	1/2 in. (13 mm) Copper Soldered Connection
Airflow (high) 0.25 in w.g. 0.5 in. w.g.	1030 CFM 890 CFM
Ventilation Airflow	100 – 140 CFM
Effectiveness (Al Core)	70%
Net Weight	150 lbs. (68 kg)
Shipping Weight	165 lbs. (75 kg)

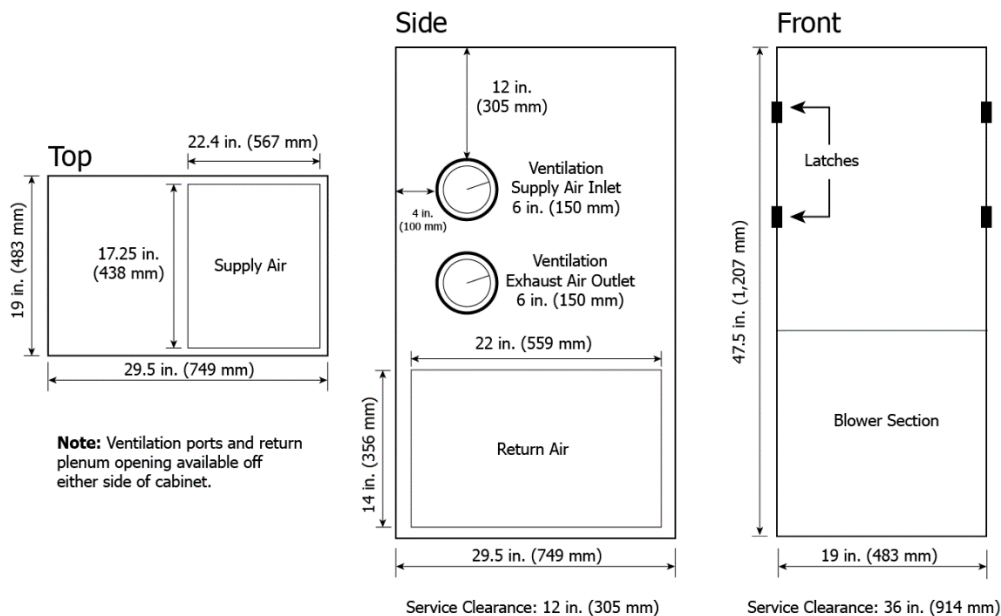

20 SPECIFICATIONS

L4A-36 Coil Output Chart (1000's of BTUH)

CFM @ 0.5" w.g.	1180	51.4	60.2	69.0	77.9	86.8	95.8
	1120	50.0	58.7	67.2	75.9	84.5	93.2
	890	43.9	51.4	60.0	66.5	74.1	81.7
	675	36.6	42.8	49.0	55.3	61.5	67.8
CFM @ 0.25" w.g.	1350	54.7	64.2	73.6	83.1	92.6	102.1
	1275	53.3	62.5	71.7	80.9	90.2	99.5
	940	45.4	53.2	60.9	68.8	76.6	84.5
	730	38.6	45.2	51.8	58.4	65.0	71.7
Water Temp. (°F)		130	140	150	160	170	180
3 GPM							

CFM @ 0.5" w.g.	1180	56.3	65.9	75.6	85.3	95.0	104.8
	1120	54.5	63.9	73.2	82.6	92.0	101.5
	890	46.9	54.9	62.9	70.9	79.0	87.1
	675	38.2	44.7	51.2	57.7	64.2	70.7
CFM @ 0.25" w.g.	1350	60.8	71.2	81.7	92.2	102.7	113.3
	1275	58.9	69.0	79.1	89.3	99.5	109.7
	940	48.7	57.0	65.3	73.7	82.1	90.4
	730	40.6	47.5	54.4	61.3	68.3	75.2
Water Temp. (°F)		130	140	150	160	170	180
4 GPM							

CFM @ 0.5" w.g.	1180	59.4	69.5	79.7	89.9	100.1	110.3
	1120	57.4	67.1	76.9	86.8	96.6	106.5
	890	48.7	56.9	65.3	73.5	81.8	90.2
	675	37.3	43.7	50.0	56.4	62.8	69.2
CFM @ 0.25" w.g.	1350	64.7	75.8	86.8	98.0	109.2	120.4
	1275	62.4	73.1	83.8	94.5	105.3	116.5
	940	50.7	59.3	67.9	76.6	85.3	94.0
	730	41.8	48.8	55.9	63.0	70.1	77.2
Water Temp. (°F)		130	140	150	160	170	180
5 GPM							

CAF-U-L4A-36-P16/E16	
Voltage	120 Vac 60 HZ
HP	1/2
Amps (total)	10.6
Water Connections	3/4 in. (19 mm) Copper Soldered Connection
Airflow (high) 0.25 in w.g. 0.5 in. w.g.	1350 CFM 1180 CFM
Ventilation Airflow	100 – 140 CFM
Effectiveness (Al Core)	70%
Net Weight	150 lbs. (68 kg)
Shipping Weight	165 lbs. (75 kg)

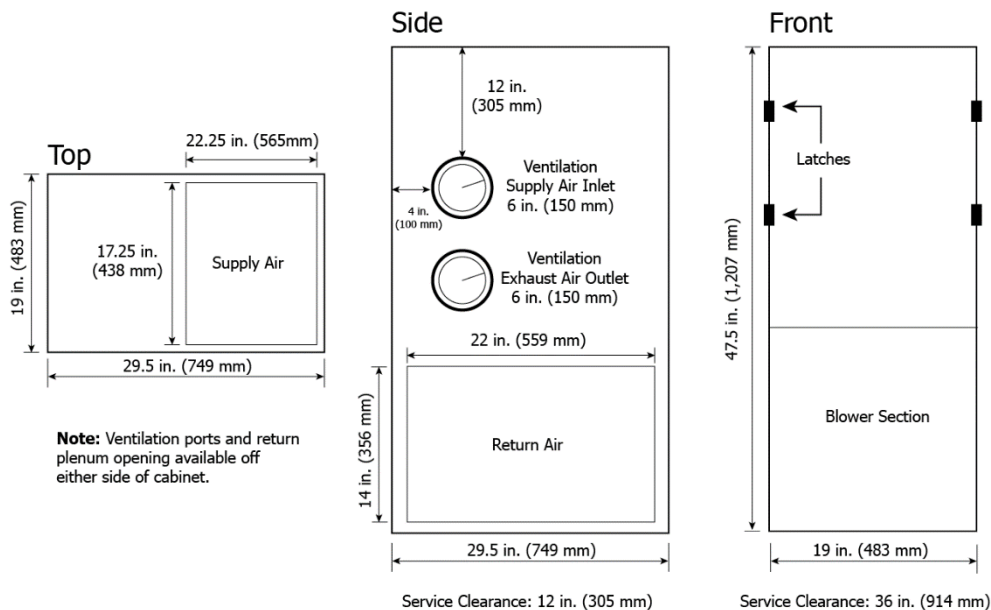

20 SPECIFICATIONS

L2A-48 Coil Output Chart (1000's of BTUH)

CFM @ 0.5" w.g.	1589	32.9	38.5	44.2	49.8	55.4	61.1
	1469	32.8	37.8	43.3	48.9	54.4	60.0
	1033	30.2	35.3	40.4	45.6	50.8	55.9
	690	24.7	28.9	33.1	37.3	41.5	45.7
CFM @ 0.25" w.g.	1888	35.1	41.0	47.0	53.1	59.1	65.1
	1650	34.6	40.4	46.4	52.3	58.2	64.2
	1134	31.2	36.5	41.8	47.1	52.4	57.8
	806	25.5	29.5	33.8	38.1	42.4	46.7
Water Temp. (°F)		130	140	150	160	170	180
3 GPM							

CFM @ 0.5" w.g.	1589	35.2	41.2	47.2	53.2	59.2	65.3
	1469	34.5	40.4	46.2	52.1	58.0	63.9
	1033	32.0	37.5	42.9	48.4	53.8	59.3
	690	25.9	30.2	34.6	39.0	43.4	47.8
CFM @ 0.25" w.g.	1888	37.7	44.1	50.6	57.0	63.5	70.0
	1650	37.1	43.4	49.8	56.1	62.5	68.9
	1134	33.2	38.8	44.4	50.1	55.8	61.4
	806	26.4	30.9	35.4	39.9	44.4	48.9
Water Temp. (°F)		130	140	150	160	170	180
4 GPM							

CFM @ 0.5" w.g.	1589	36.7	43.0	49.2	55.4	61.7	68.0
	1469	36.0	42.0	48.1	54.3	60.4	66.5
	1033	33.3	38.9	44.5	50.2	55.8	61.5
	690	26.6	31.1	35.6	40.1	44.6	49.1
CFM @ 0.25" w.g.	1888	39.5	46.2	52.9	59.7	66.4	73.2
	1650	38.8	45.4	52.0	58.7	65.3	71.9
	1134	34.5	40.3	46.2	52.0	57.9	63.8
	806	27.2	31.8	36.4	41.0	45.6	50.2
Water Temp. (°F)		130	140	150	160	170	180
5 GPM							

CAF-U-L2A-48-P16/E16	
Voltage	120 Vac 60 HZ
HP	1/2
Amps (total)	10.6
Water Connections	1/2 in. (13 mm) Copper Soldered Connection
Airflow (high) 0.25 in w.g. 0.5 in. w.g.	1589 CFM 1388 CFM
Ventilation Airflow	100 – 140 CFM
Effectiveness (Al Core)	70%
Net Weight	150 lbs. (68 kg)
Shipping Weight	165 lbs. (75 kg)

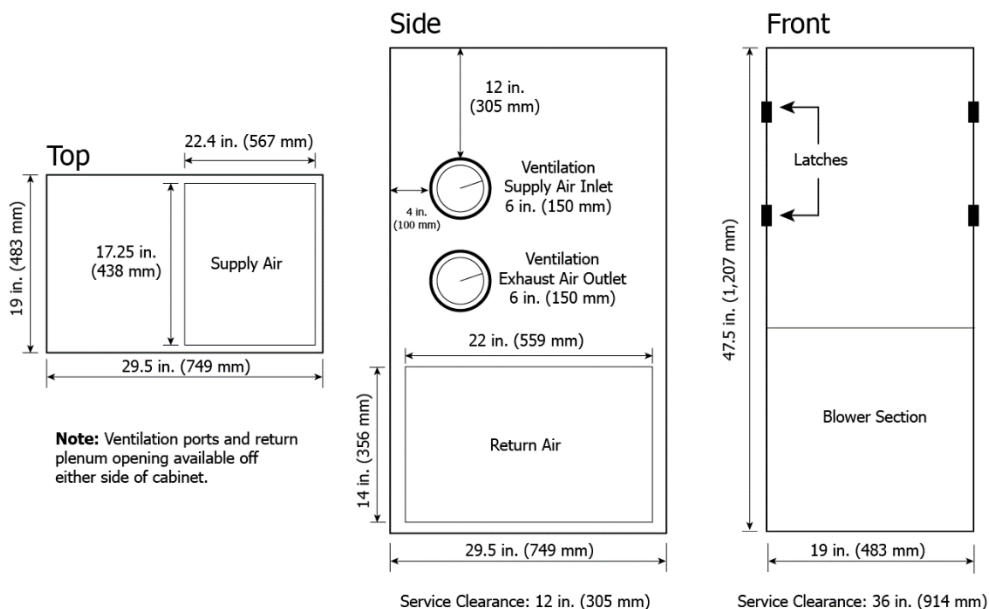

21 SYSTEM COMMISSIONING

This section of the manual is designed to be used with the "Commissioning of Integrated Combo System" worksheet. The worksheet is designed to guide you through the start-up process in a logical, step by step method which should minimize the work and time involved in having the system meet the designed parameters.

The following conditions are assumed:

- The air filter is in place.
- All supply diffusers and return grilles are fully open and unrestricted.
- Hot water is available to the furnace.
- The drain valve for the heating loop is closed.
- The shut-off valves for the heating loop are fully open.
- The throttling valve for the heating loop (if applicable), is fully opened.
- Electrical power is available to the furnace.
- The return air temperature from house is approximately 70°F (21°C).

Commissioning of Integrated Combo System	
Designer/Signature: _____	
Phone: _____ E-mail: _____ Date: _____	
<p style="text-align: center;">Submitted For: (Owner)</p> <p>Name: _____</p> <p>Address: _____</p> <p>City: _____ Province: _____</p> <p>Postal Code: _____</p> <p>Phone: _____ E-mail: _____</p>	<p style="text-align: center;">By: (Contractor)</p> <p>Name: _____</p> <p>Address: _____</p> <p>City: _____ Province: _____</p> <p>Postal Code: _____</p> <p>Phone: _____ E-mail: _____</p>

Installed Equipment	
<ul style="list-style-type: none"> <input type="checkbox"/> Water Heater make & model as designed <input type="checkbox"/> Air Handler make & model as designed <input type="checkbox"/> Cooling Unit make & model as designed <input type="checkbox"/> Filter type and size as designed <input type="checkbox"/> 2 shut off valves for heating loop <input type="checkbox"/> Check Valve <input type="checkbox"/> Drain Valve 	<ul style="list-style-type: none"> <input type="checkbox"/> Throttling Valve <input type="checkbox"/> Anti-scalding Valve <input type="checkbox"/> Back Flow Prevention valve <input type="checkbox"/> Expansion Tank <input type="checkbox"/> Off Season Circulation Controls <input type="checkbox"/> Other

21 SYSTEM COMMISSIONING

System Start Up	
<input type="checkbox"/> Fill Water-Heater with water <input type="checkbox"/> Set Water-Heater at designed temperature <input type="checkbox"/> Fill Heating Loop with water <input type="checkbox"/> Purge Circulation Pump	<input type="checkbox"/> Start Air Handler <input type="checkbox"/> Check Circulation Pump Operation <input type="checkbox"/> Check Circulation Fan Operation <input type="checkbox"/> Label Water-Heater

HRV Balancing
<input type="checkbox"/> Exhaust Air Flow _____ <input type="checkbox"/> Fresh Air Intake Air Flow _____ <input type="checkbox"/> Back Draft Damper installed in Stale Air to Outside Duct

System Commissioning			
<input type="checkbox"/> Total Heat Loss <input type="checkbox"/> Air Handler Output <input type="checkbox"/> Eff. Water-Heater Output <input type="checkbox"/> Air Handler ESP <input type="checkbox"/> Air Flow Rate <input type="checkbox"/> Fan Speed	_____ Btu/h _____ Btu/h _____ Btu/h _____ in. W.C. _____ CFM _____	<input type="checkbox"/> Supply Water Temperature <input type="checkbox"/> Return Water Temperature <input type="checkbox"/> Supply Air Temperature <input type="checkbox"/> Return Air Temperature	_____ °F _____ °F _____ °F _____ °F _____ °F
a. Supply Water Temperature <i>(measured)</i> b. Air Handler Output (at a) c. Air Handler Operating CFM <i>(measured)</i> d. Return Air Temperature <i>(measured)</i> e. Required Air Temperature Difference (b / (1.08 x c))	_____ °F _____ Btu/h _____ CFM _____ °F _____ °F	f. Required Supply Air Temperature (d + e) g. Returned Water Temperature (<i>measured</i>) h. Water Temperature Difference (a – g) i. Actual Supply Air Temperature (<i>measured</i>) j. Anti-Scald valve Outlet Temperature (<i>measured</i>)	_____ °F _____ °F _____ °F (<i>min. 20°F</i>) _____ °F _____ °F

22 WIRING DIAGRAMS (STANDARD MOTOR)

CAUTION

Electrical control panel service by electrician only. Disconnect electrical supply prior to servicing. Improper wiring may result in damage to this unit. Use copper supply wires.

ATTENTION

Entretien du panneau de contrôle électrique par un électricien seulement. Coupez l'alimentation électrique avant de procéder à l'entretien. Un câblage inadéquat pourrait endommager cet appareil. Utilisez des câbles de cuivre

Standard Motor CAF/Air Handler Wiring Diagram

Schéma de câblage d'un moteur de FAP/Appareil de traitement de l'air standard

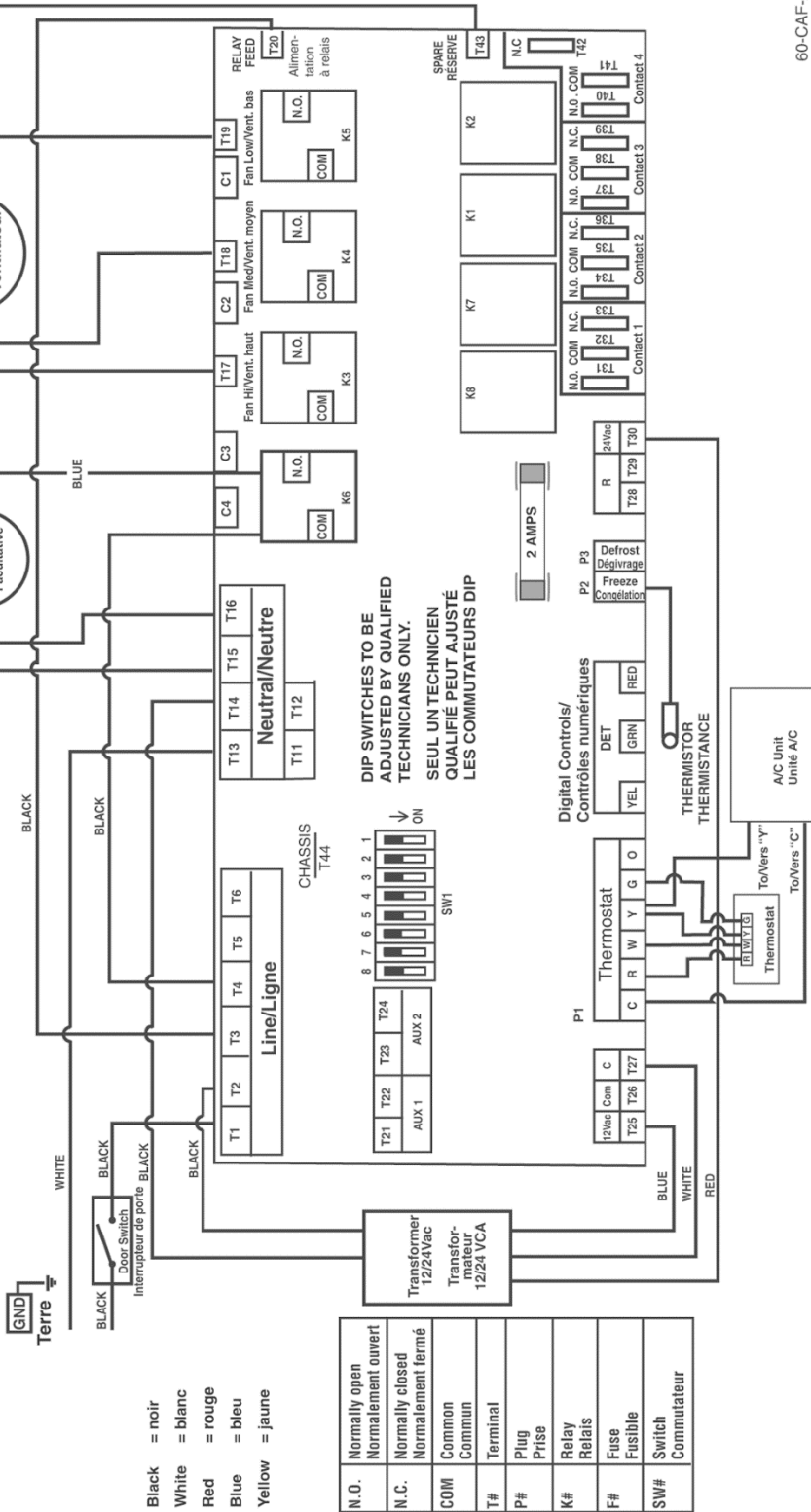

60-CAF-AH-01

23 WIRING DIAGRAMS (ECM)

CAUTION

Electrical control panel service by electrician only. Disconnect electrical supply prior to servicing. Improper wiring may result in damage to this unit. Use copper supply wires.

ATTENTION

Entretien du panneau de contrôle électrique par un électricien seulement. Coupez l'alimentation électrique avant de procéder à l'entretien. Un câblage inadéquat pourrait endommager cet appareil. Utilisez des câbles de cuivre.

ECM - CAF/Air Handler Wiring Diagram/

Schéma de câblage FAP/Appareil de traitement de l'air - moteur à commutation électronique ECM

- Black = noir
- White = blanc
- Red = rouge
- Blue = bleu
- Yellow = jaune
- Tan = havane
- Purple = pourpre
- Brown = brun

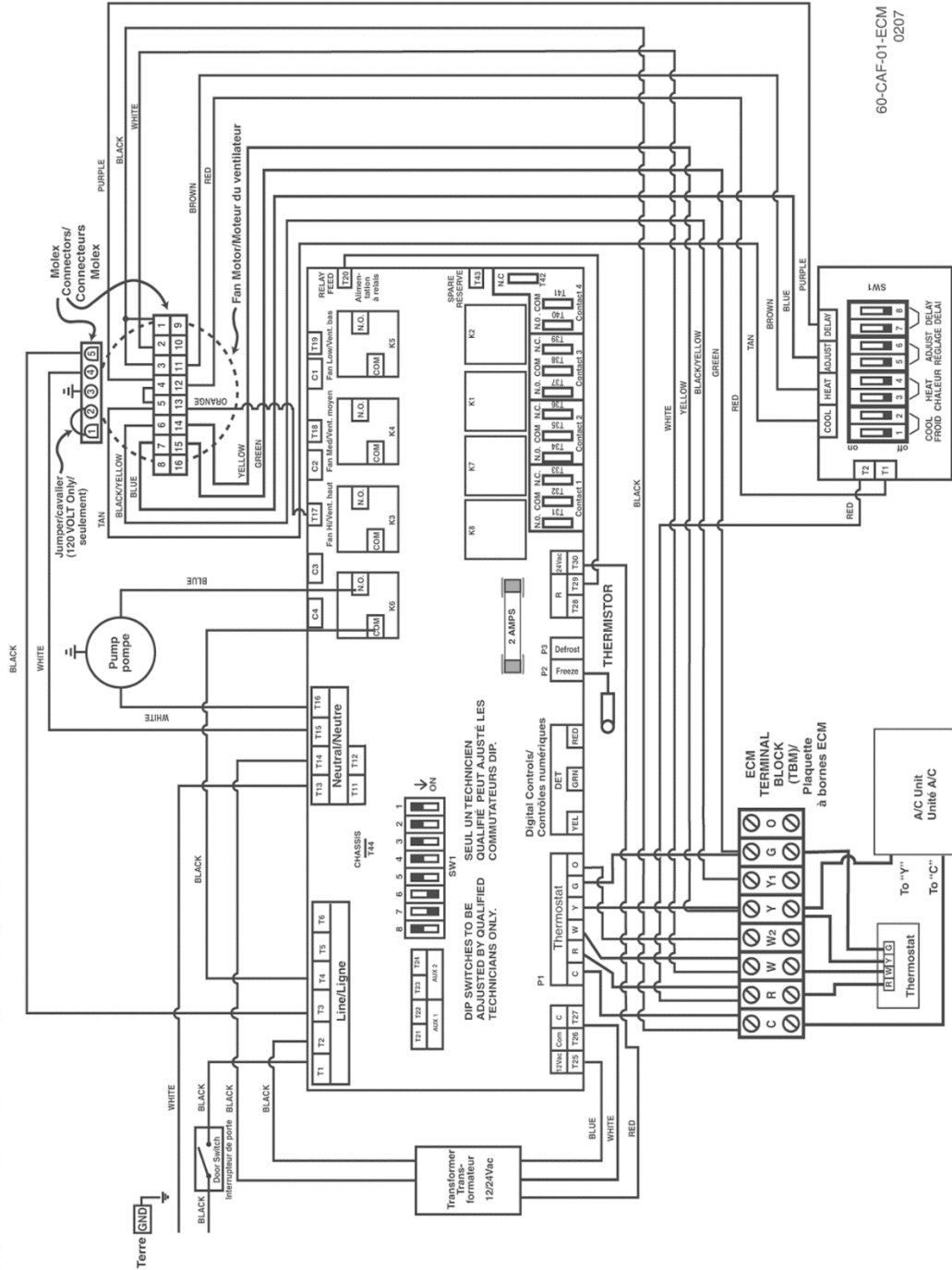

N.O.	Normally open Normalement ouvert
N.C.	Normally closed Normalement fermé
COM	Common Commun
T#	Terminal
P#	Plug Prise
K#	Relay Relais
F#	Fuse Fusible
SW#	Switch Commutateur

60-CAF-01-ECM
0207

24 LIFE BREATH LIMITED WARRANTY

AIRIA BRANDS INC.® (AIRIA) warrants to the original purchaser of the LIFE BREATH® model and accessories referred to below, to be free from manufacturing defects.

This Limited Warranty is personal to AIRIA® and is in effect from the installation date, but no later than 12 months after the date the product was manufactured (if the installation date cannot be verified, the warranty period will begin on the date of manufacture). The serial number can be used to determine the date of manufacture: XX XX MMDDYY ###; or MMDDYY ###. The warranty is dependent on the type of unit:

Type of Unit	Warranty
HRV Residential	Lifetime on the Core / 5 years on other components
HRV Commercial	15 years on the Core / 2 years on other components
ERV Residential	5 years on the Core / 5 years on other components
ERV Commercial	5 years on the Core / 2 years on other components
Accessories (e.g. controls and timers)	1 year
Replacement Parts (e.g. motor)	1 year
Clean Air Furnace (HRV)	Lifetime on the Core / 2 years on other components
Clean Air Furnace (ERV)	5 years on the Core / 2 years on other components
Air Handler	5 years
TFP	5 years

Damage resulting from all other causes, including but not limited to: lightning, hurricane, tornado, earthquake or any other acts of God; improper installation, modification, alteration or misuse of the LIFE BREATH® unit or its operation in a manner contrary to the instructions accompanying the unit at the time of sale; accidental or intentional damage, neglect, improper care, or other failure by the owner to provide reasonable and necessary maintenance of the product; any attempt at repair by an unauthorized service representative or not in accordance with this warranty; or any other causes beyond the control of AIRIA®, are excluded from this warranty.

If you feel that the LIFE BREATH® unit you purchased is not free from manufacturing defects, please refer to <https://www.lifebreath.com/homeowners-2/find-a-contractor/> to find the name of your nearest dealer in order to repair the product. The labour required to install any replacement part(s) is not covered by AIRIA®.

AIRIA® reserves the right to replace the entire unit or to refund the original purchase price in lieu of repair.

AIRIA® MAKES NO EXPRESS WARRANTIES, EXCEPT FOR THOSE THAT SET FORTH HEREIN AND SHALL NOT BE LIABLE FOR ANY INCIDENTAL, SPECIAL OR CONSEQUENTIAL DAMAGES WITH RESPECT TO LIFE BREATH® COVERED BY THIS WARRANTY. AIRIA'S COMPLETE LIABILITY AND THE OWNER'S EXCLUSIVE REMEDY BEING LIMITED TO REPAIR OR REPLACEMENT ON THE TERMS STATED HEREIN. ANY IMPLIED WARRANTIES, INCLUDING BUT NOT LIMITED TO THE IMPLIED WARRANTY OF MERCHANTABILITY AND OF FITNESS FOR ANY PARTICULAR PURPOSE, ARE EXPRESSLY EXCLUDED.

NO PERSON IS AUTHORIZED TO CHANGE THE WARRANTY IN ANY WAY OR GRANT ANY OTHER WARRANTY UNLESS SUCH CHANGES ARE MADE IN WRITING AND SIGNED BY AN OFFICER OF AIRA®.

MODEL NO.: _____

UNIT SERIAL NO.: _____

INSTALLED BY: _____

DATE: _____